

Tries and Suffix Trees

Pollev Test Run

What is your favorite book?

Answer at

<https://pollev.com/cs166spr23>

String Data Structures

- Our next topic for the quarter is the wonderful world of string data structures.
- Why are they worth studying?
 - ***They're practical.*** These data structures were developed to meet practical needs in data processing. Lots of important data can be encoded as strings.
 - ***They're different.*** The questions typically asked about strings involve properties of sequences, not individual elements, in a way that you don't normally otherwise see.
 - ***They're algorithmically interesting.*** The techniques that power these data structures involve some truly beautiful connections and observations.

Where We're Going

- Today, we'll cover *tries* and *suffix trees*, two powerful data structures for exposing shared structures in strings.
- On Thursday, we'll see the *suffix array* and *LCP array*, which are a more space-efficient way of encoding suffix trees.

Part I: *Tries and Patricia Tries*

A Motivating Problem



what is the cutest ani|



- what is the cutest animal in the world
- what is the cutest animal
- what is the cutest animal on earth
- what is the cutest animal ever
- what is the cutest animal in the whole entire world
- what is the cutest animal in the whole world
- what is the cutest animal alive
- what is the cutest animal on the planet
- what is the cutest animal in australia
- what is the cutest animal in the sea

Google Search

I'm Feeling Lucky

Report inappropriate predictions

How is this done so quickly?

The Autocomplete Problem

- We have a series of text strings T_1, T_2, \dots, T_k of total length m . ($|T_1| + \dots + |T_k| = m$)
- We have a pattern string P of length n . ($|P| = n$).
- **Goal:** Find all text strings that start with P .
- If we just do a single query, then we can solve this pretty easily.
 - Just scan over all the strings and see which ones start with P .
- **Question:** If we have a set of fixed text strings and varying patterns, can we speed this up?

A Naive Solution

a n t

a n t e

a n t e a t e r

a n t e l o p e

a n t i q u e

a n t e

We're spending a lot of time scanning shared prefixes. Is there a way to avoid this?

ant
ante
anteater
antelope
antique

This data structure is called a **trie**. It comes from the word **retrieval**. It is not pronounced like "retrieval."

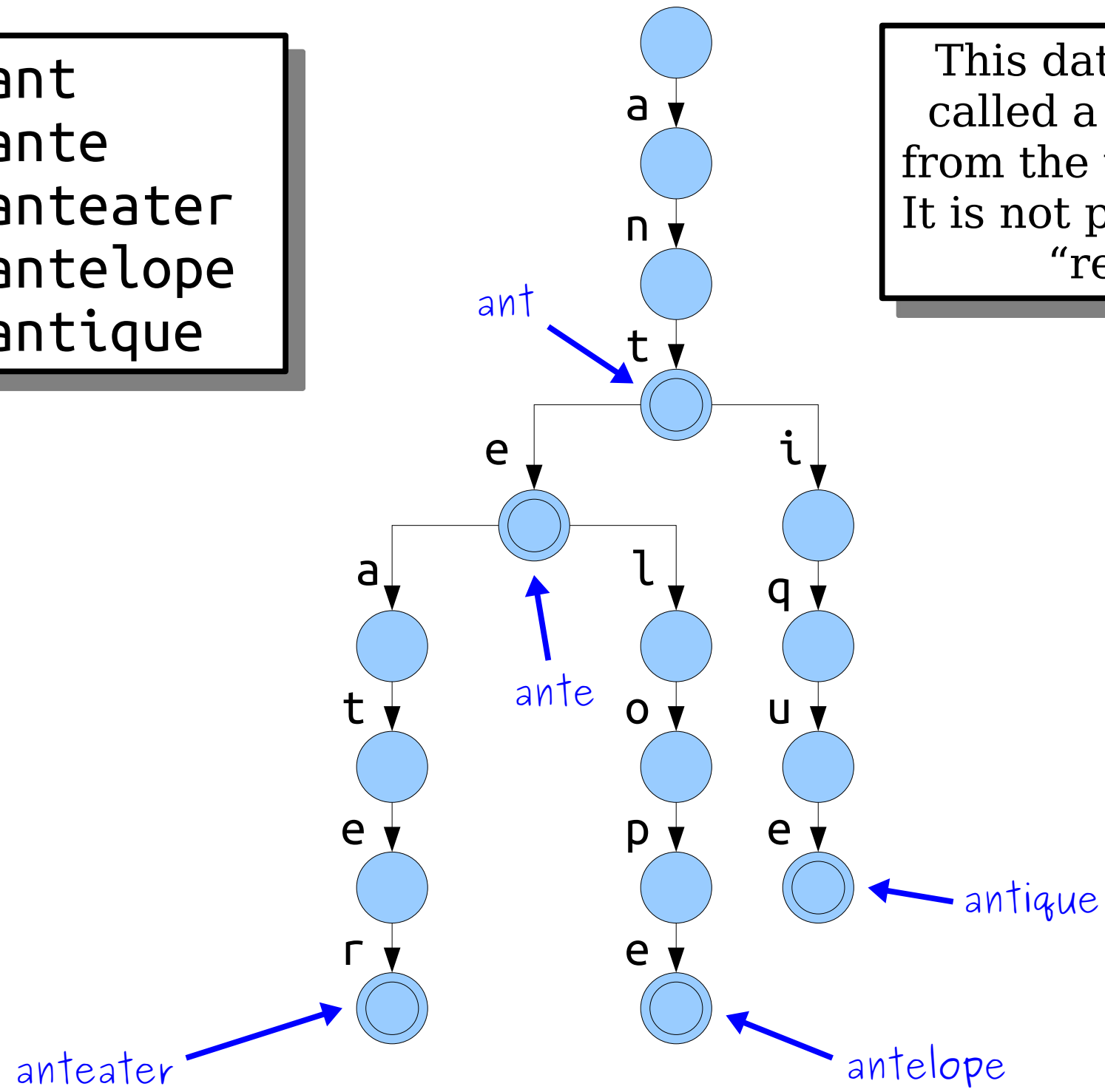

ant
ante
anteater
antelope
antique

Each edge is labeled with a character.
Some nodes are marked as representing words.
By convention, children are stored in sorted order.
A preorder traversal of the trie prints all words in sorted order.

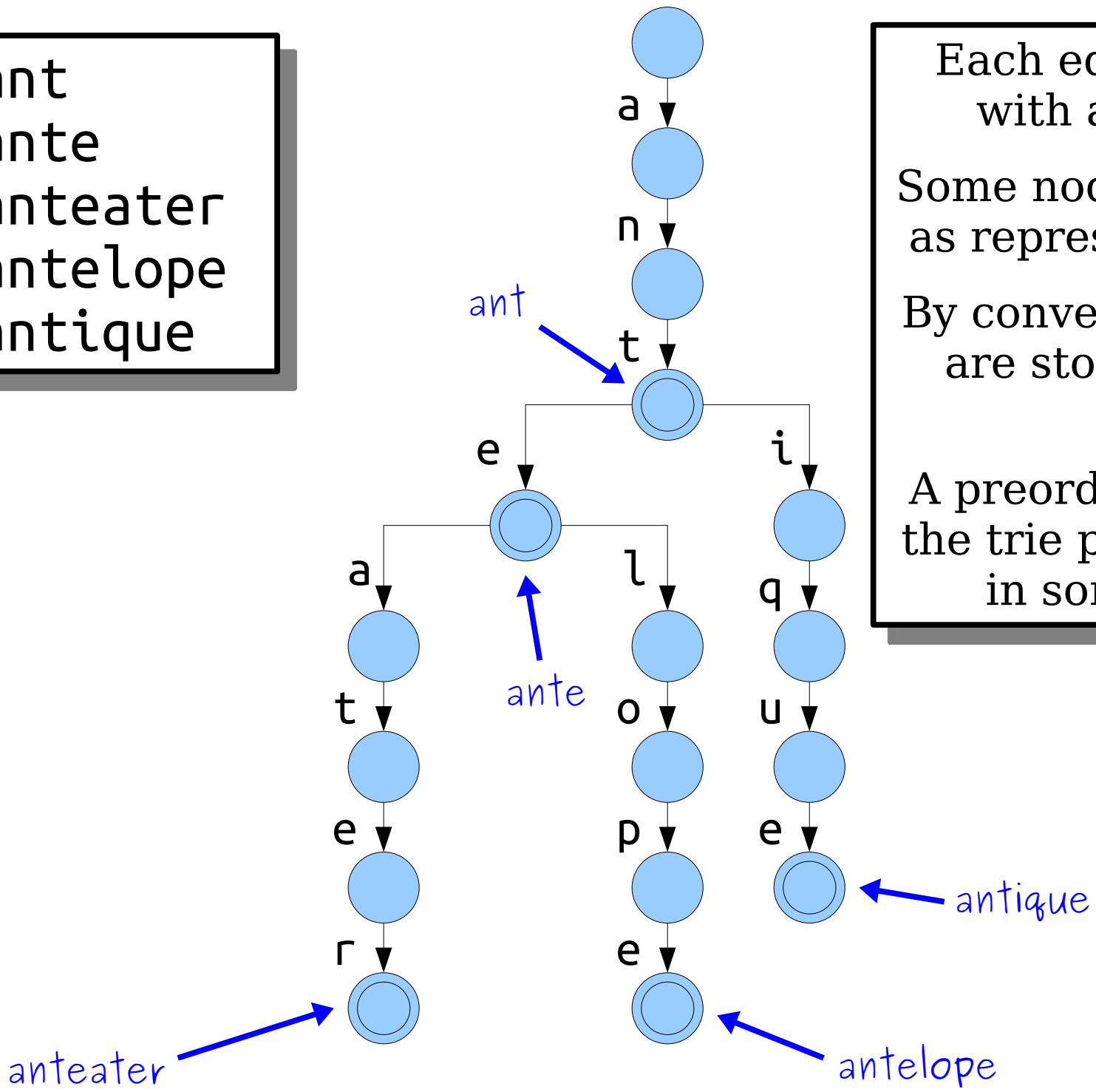

ant
ante
anteater
antelope
antique

a n t e

Now, do a DFS to find all words rooted here.

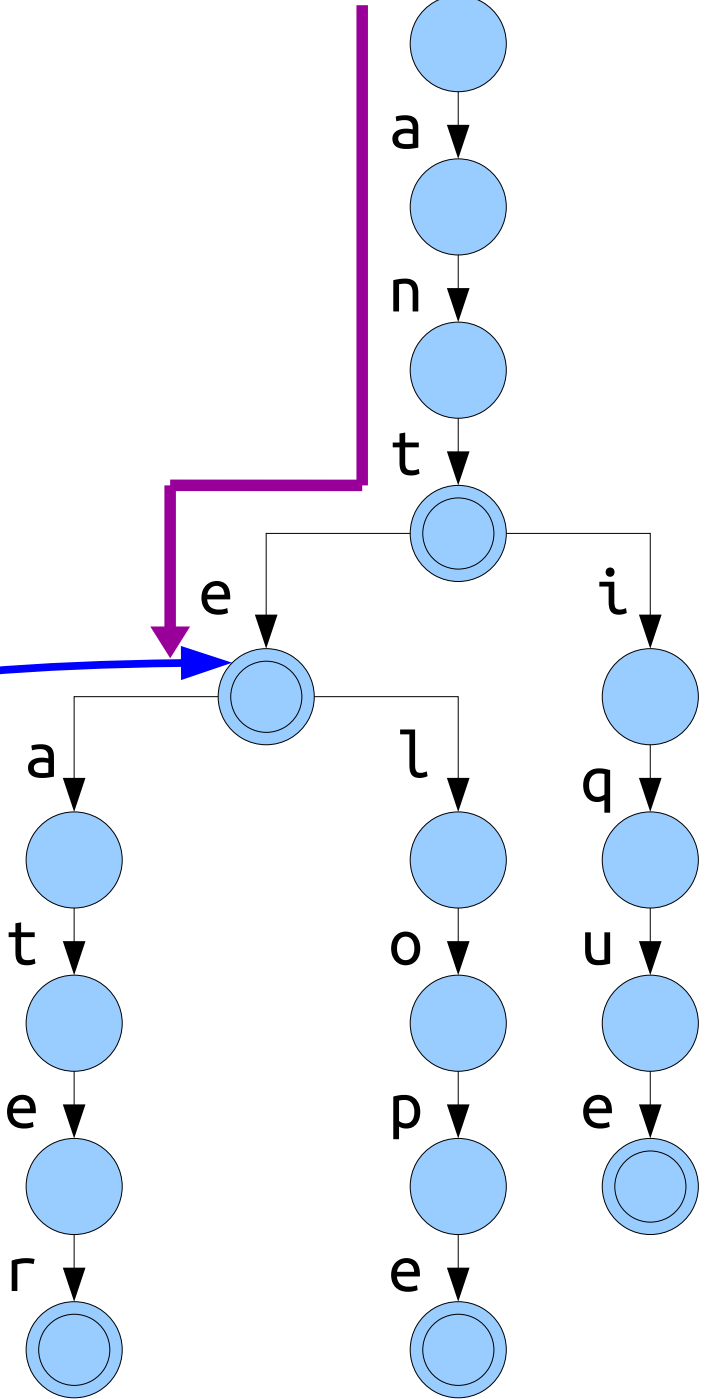

ant
ante
anteater
antelope
antique

a n t w

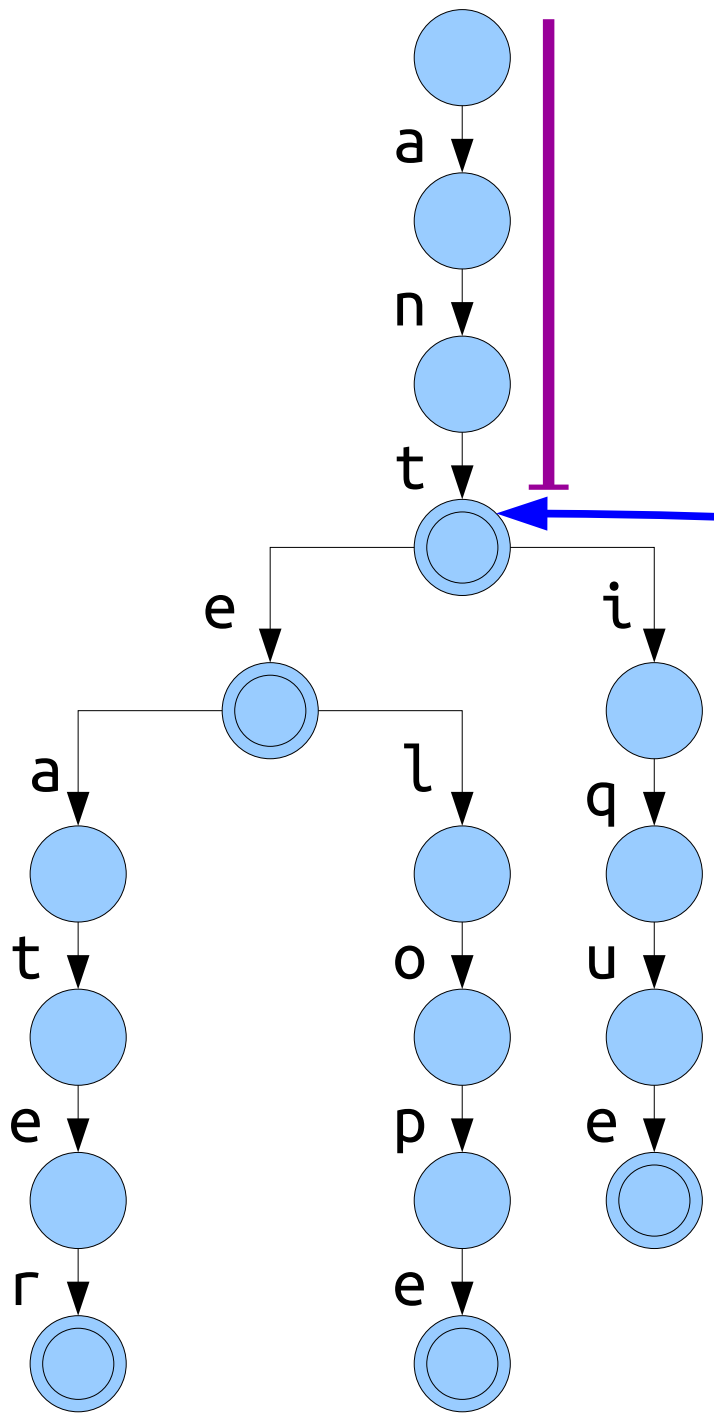

We fell off
the trie.
There are no
matches!

Tries

- **Recall:** The total length of our text strings is m , and the length of our pattern string is n .
- How long does it take to check if the pattern is a prefix of any string?
- **Claim:** Ignoring the size of the alphabet, the runtime is $O(n)$.

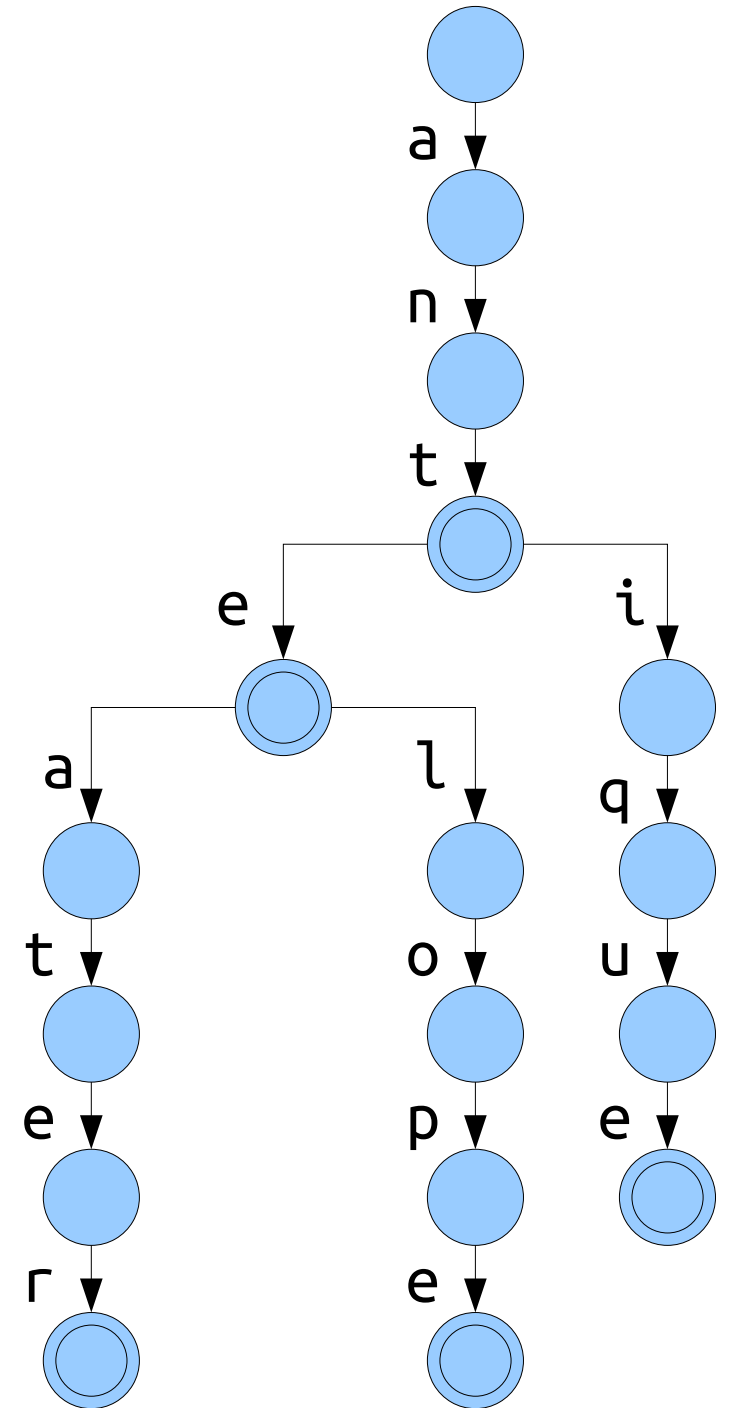

Tries

- **Recall:** The total length of our text strings is m , and the length of our pattern string is n .
- How long does it take to find all text strings that start with the pattern?
- That's a trickier question.

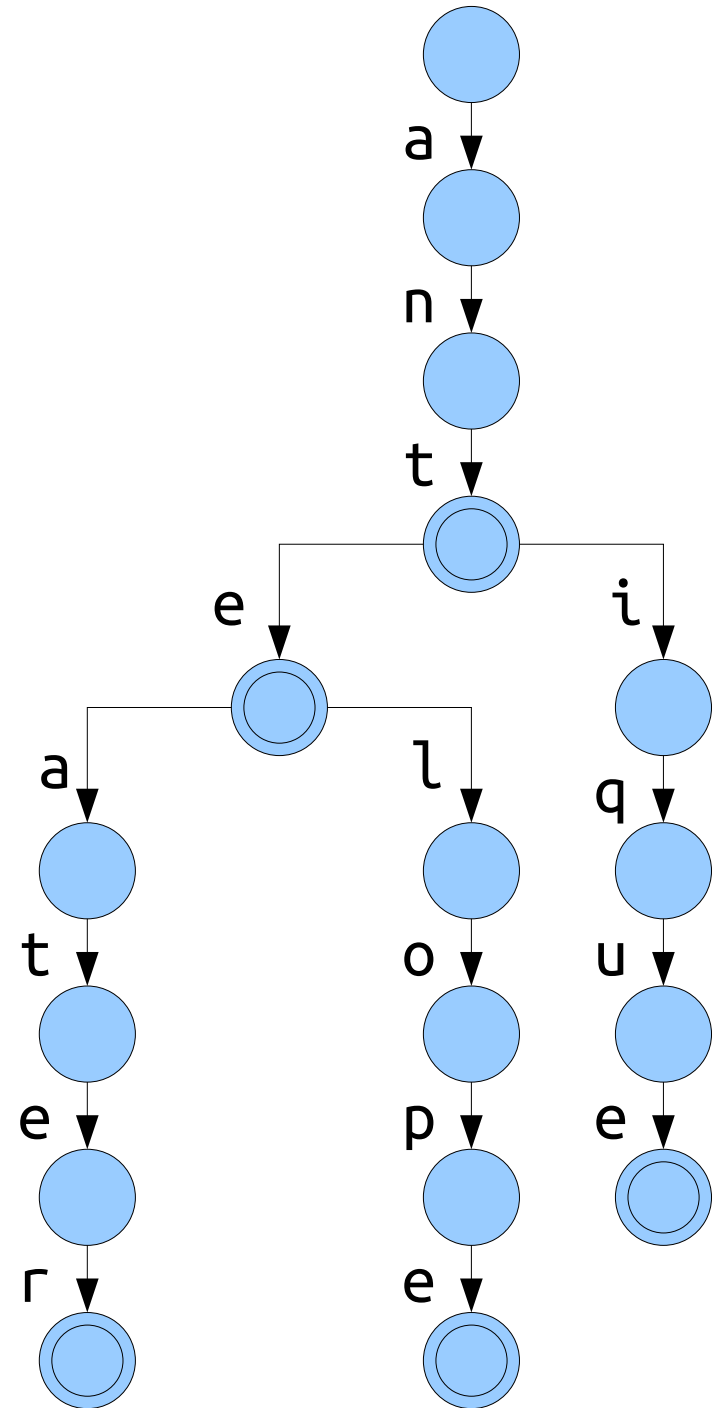

Tries

- **Question:** In what format do we want our matches?
- **Option 1:** Just print out all the matches.
 - Search for the prefix as usual.
 - Do a DFS, recording the letters seen on each branch, to rebuild all the words.
- We can upper-bound runtime at $O(m + n)$, but it's hard to say much more than that.
 - (We could upper-bound this expression at $O(m)$ if we'd like, but I like showing both costs here.)

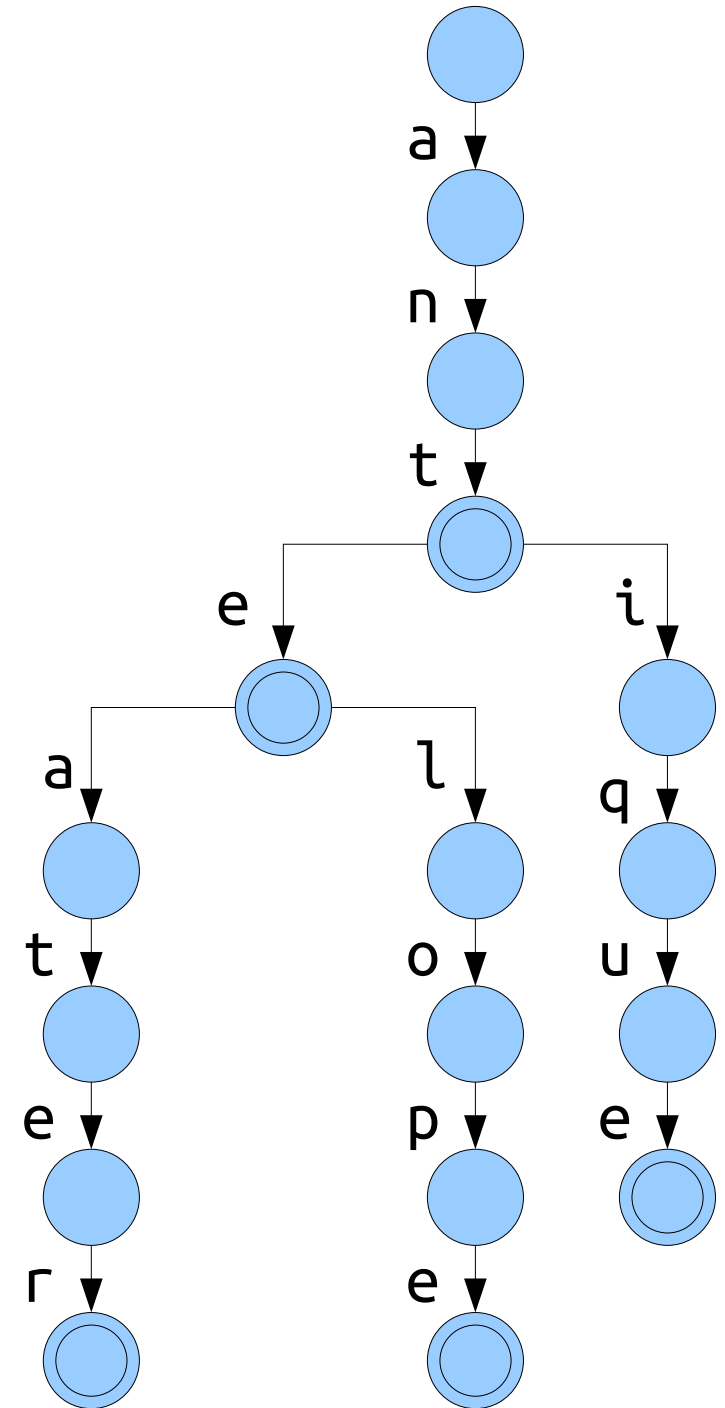

Tries

- **Question:** In what format do we want our matches?
- **Option 2:** Assume each text string has some numeric ID, and we want all matching IDs.
- Ideally, we'd like a time complexity of something like $O(n + z)$, where z is the number of matches.
- Our current DFS can't achieve this; the lengths of the strings matter.
- Can we do better?

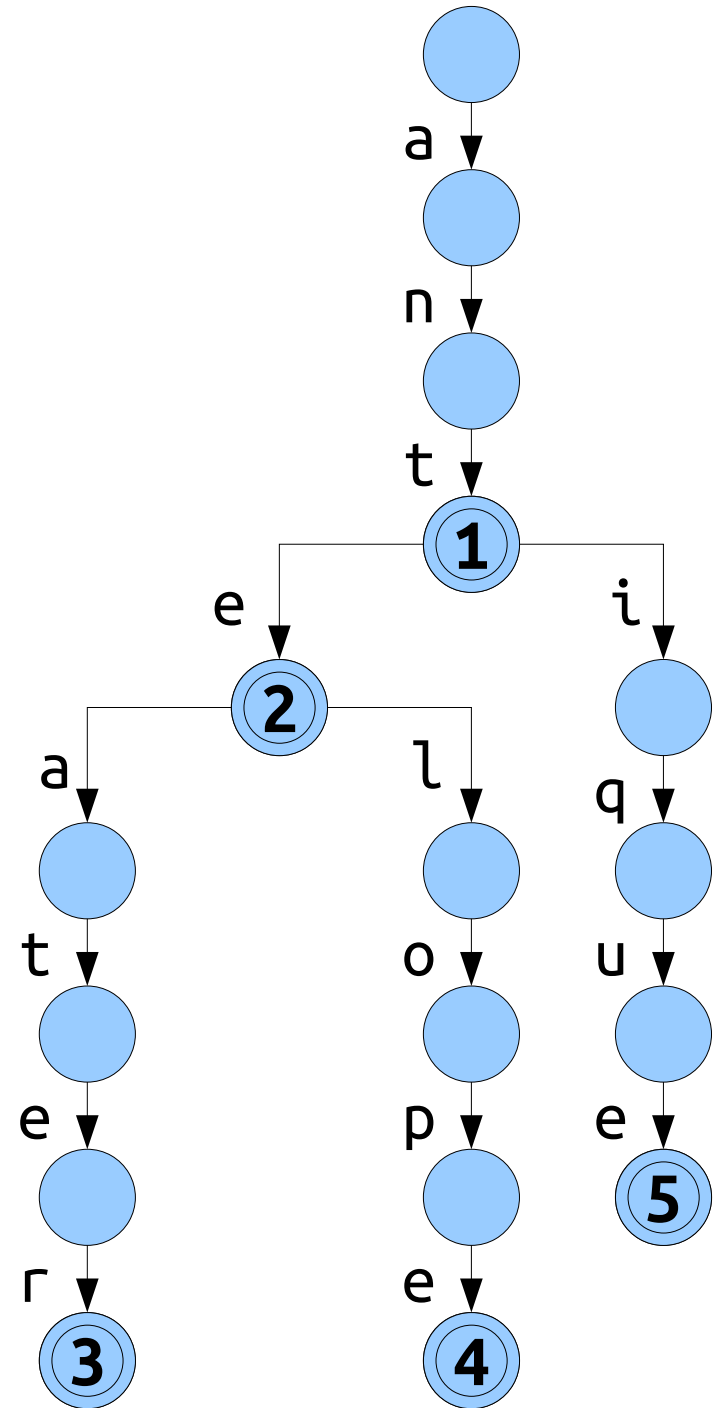

ant
ante
anteater
antelope
antique

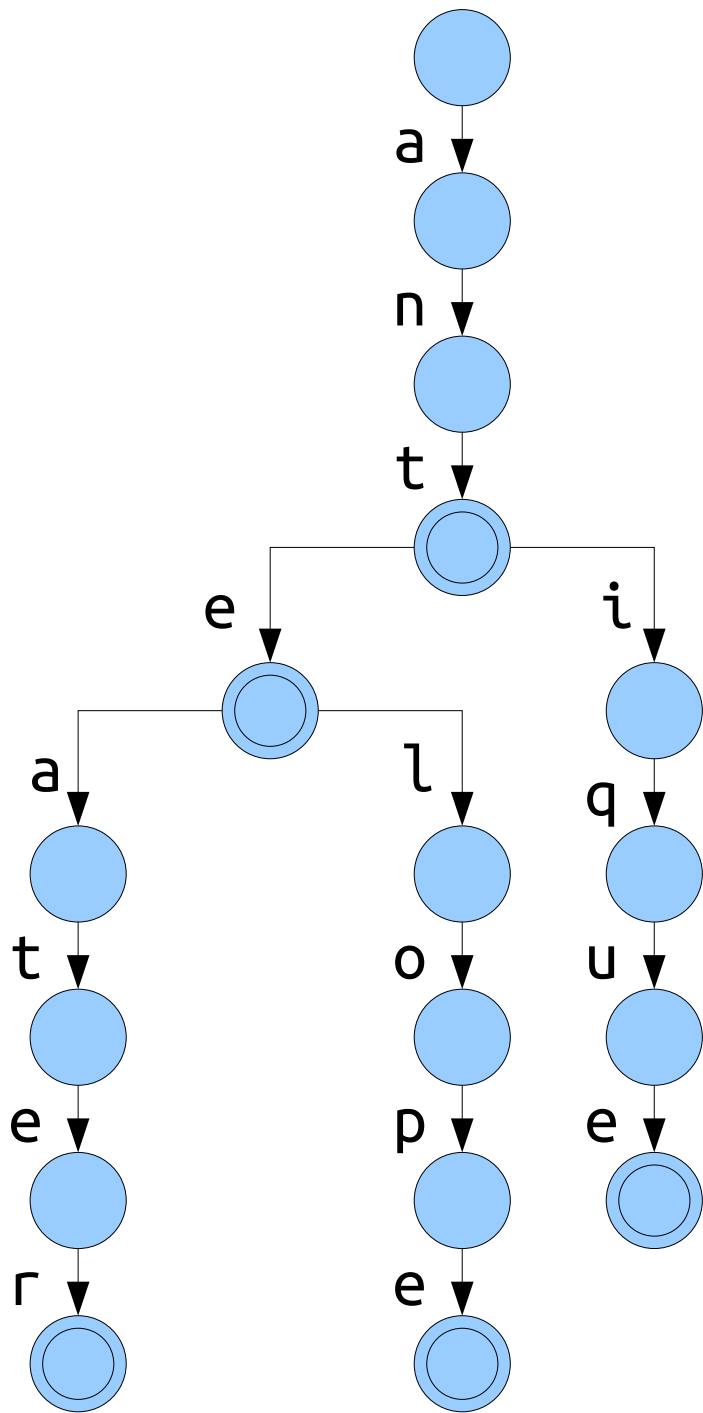

ant\$
ante\$
anteater\$
antelope\$
antique\$

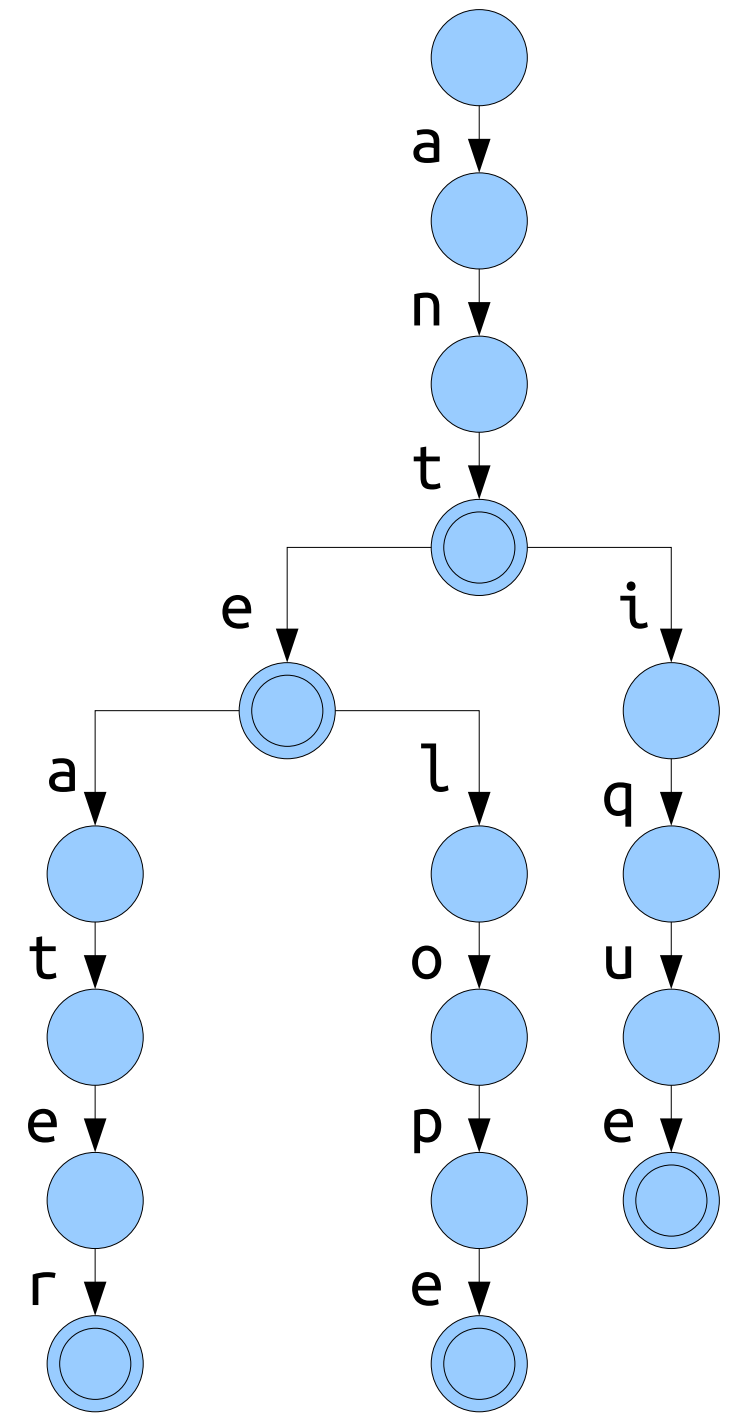

ant\$
ante\$
anteater\$
antelope\$
antique\$

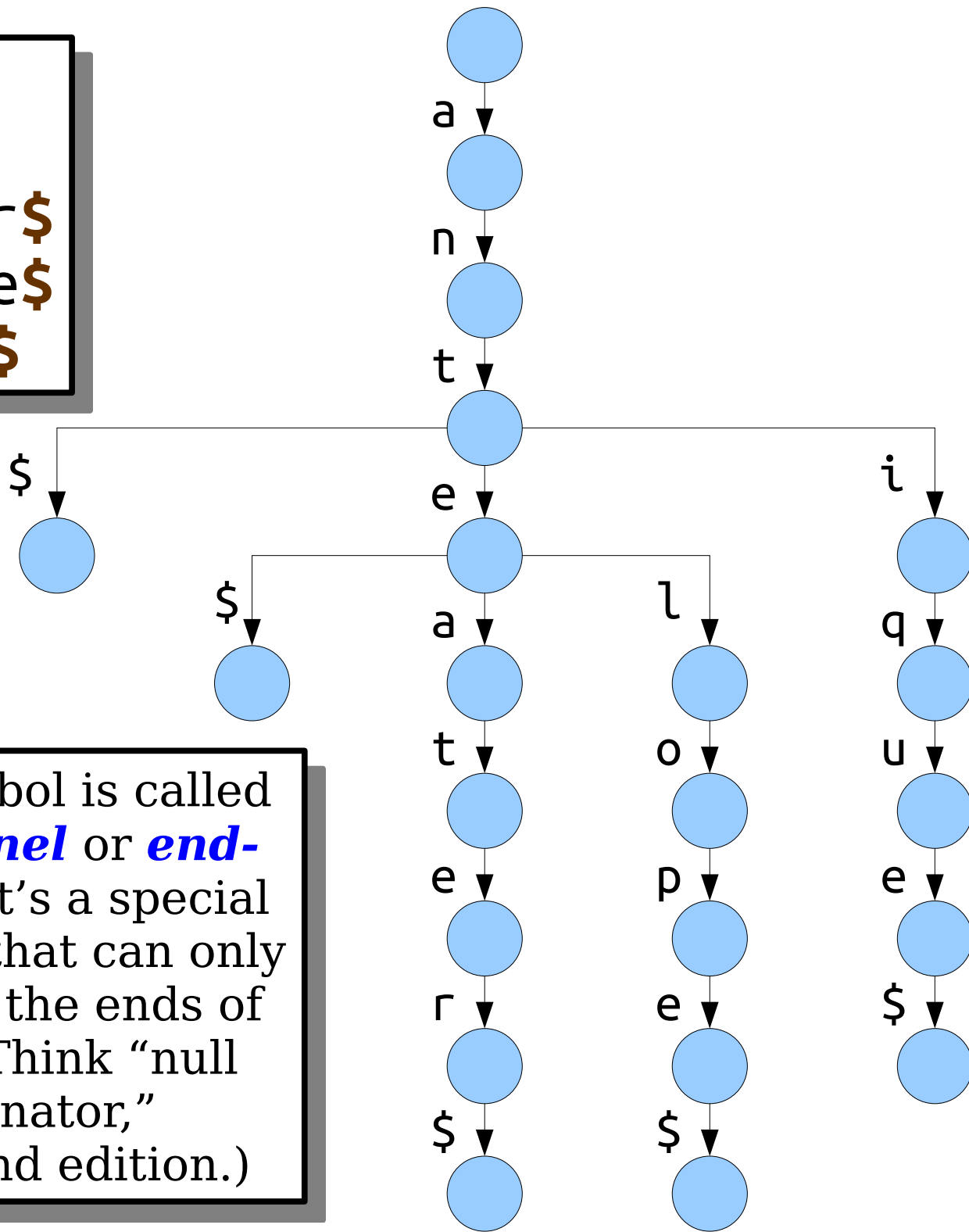

The **\$** symbol is called the **sentinel** or **end-marker**. It's a special character that can only appear at the ends of words. (Think "null terminator," Theoryland edition.)

ant\$
ante\$
anteater\$
antelope\$
antique\$

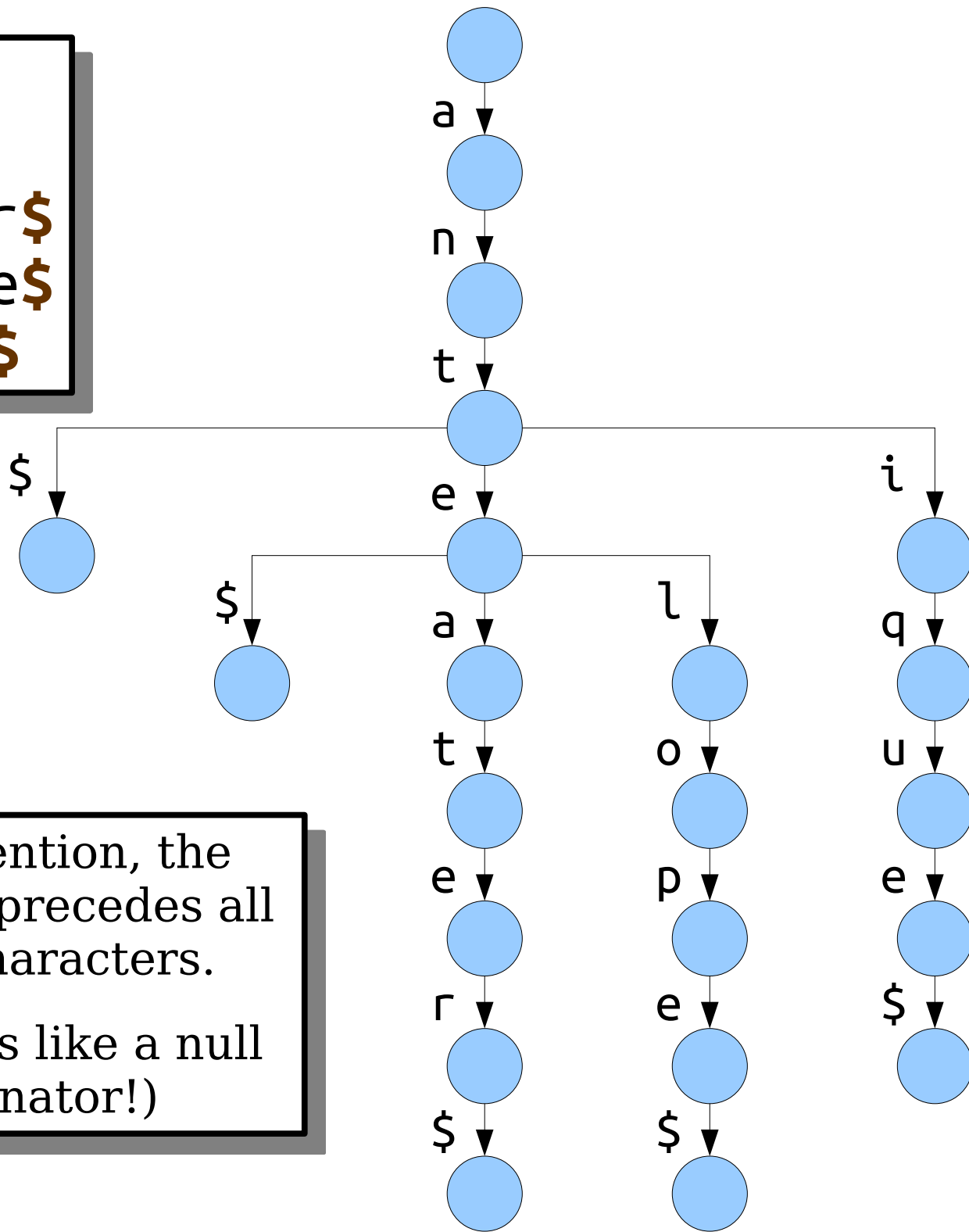

By convention, the sentinel \$ precedes all other characters.

(It really is like a null terminator!)

ant\$
ante\$
anteater\$
antelope\$
antique\$

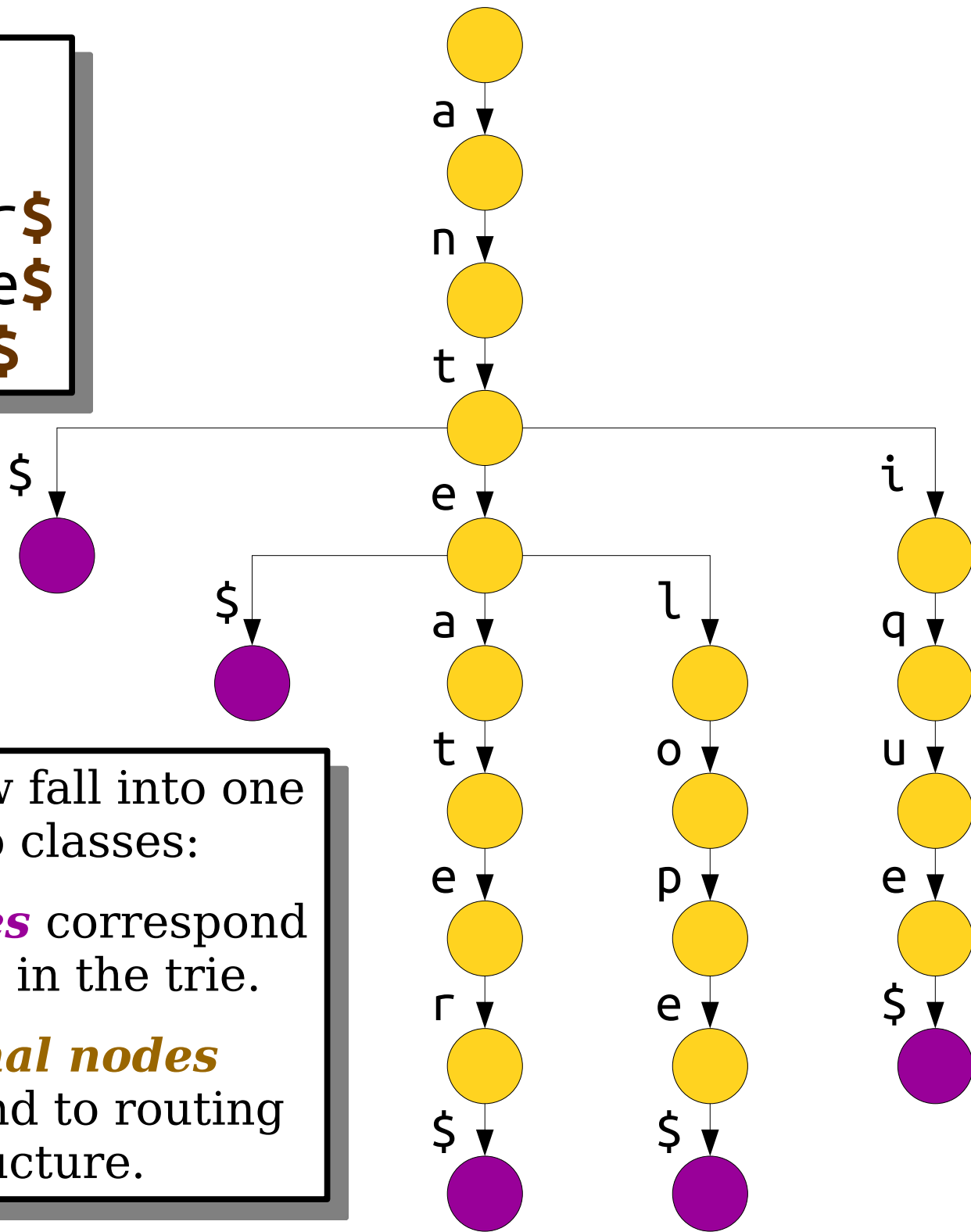

Nodes now fall into one of two classes:

Leaf nodes correspond to words in the trie.

Internal nodes correspond to routing structure.

ant\$
 ante\$
 anteater\$
 antelope\$
 antique\$

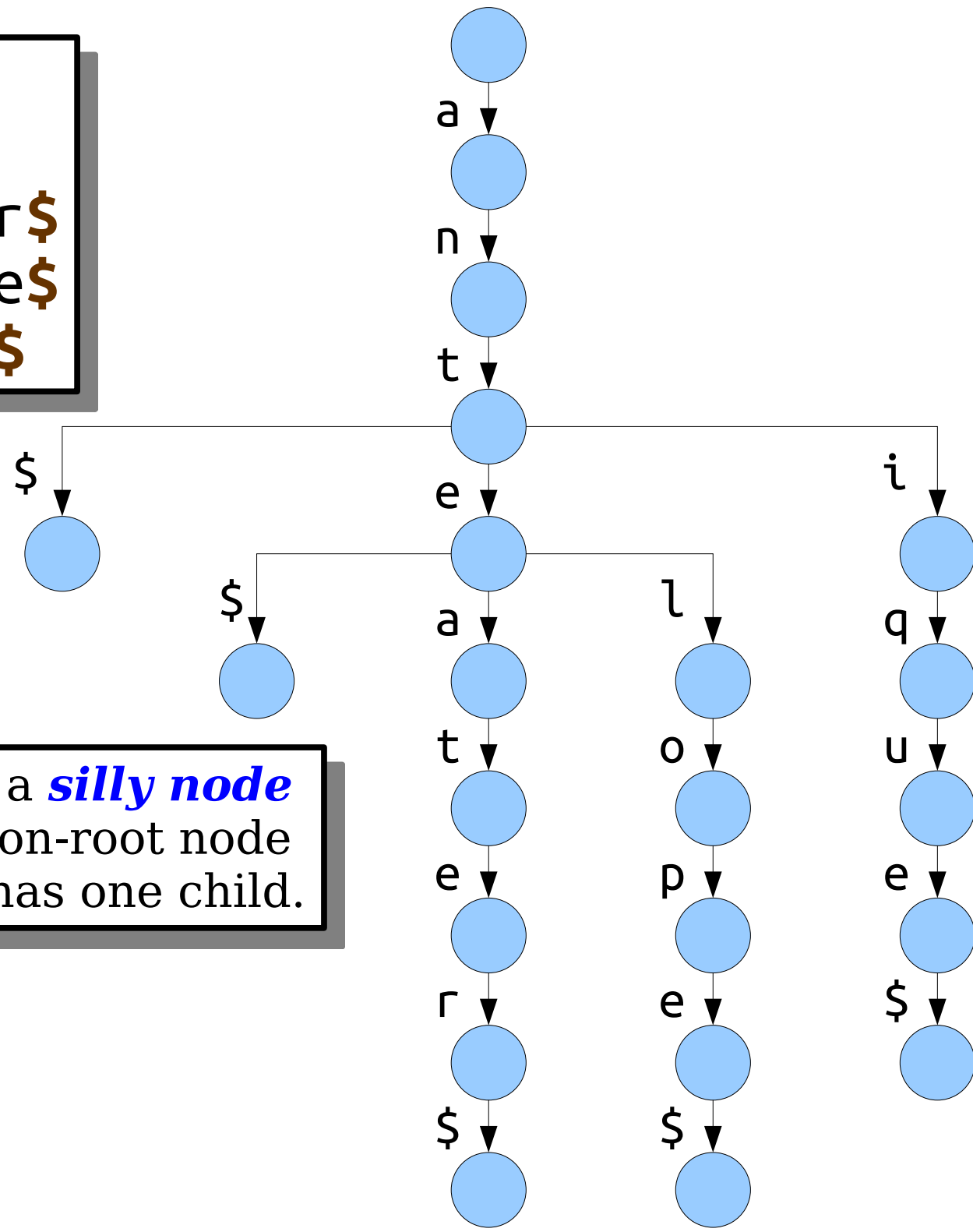

A node is a ***silly node*** if it is a non-root node that only has one child.

ant\$
 ante\$
 anteater\$
 antelope\$
 antique\$

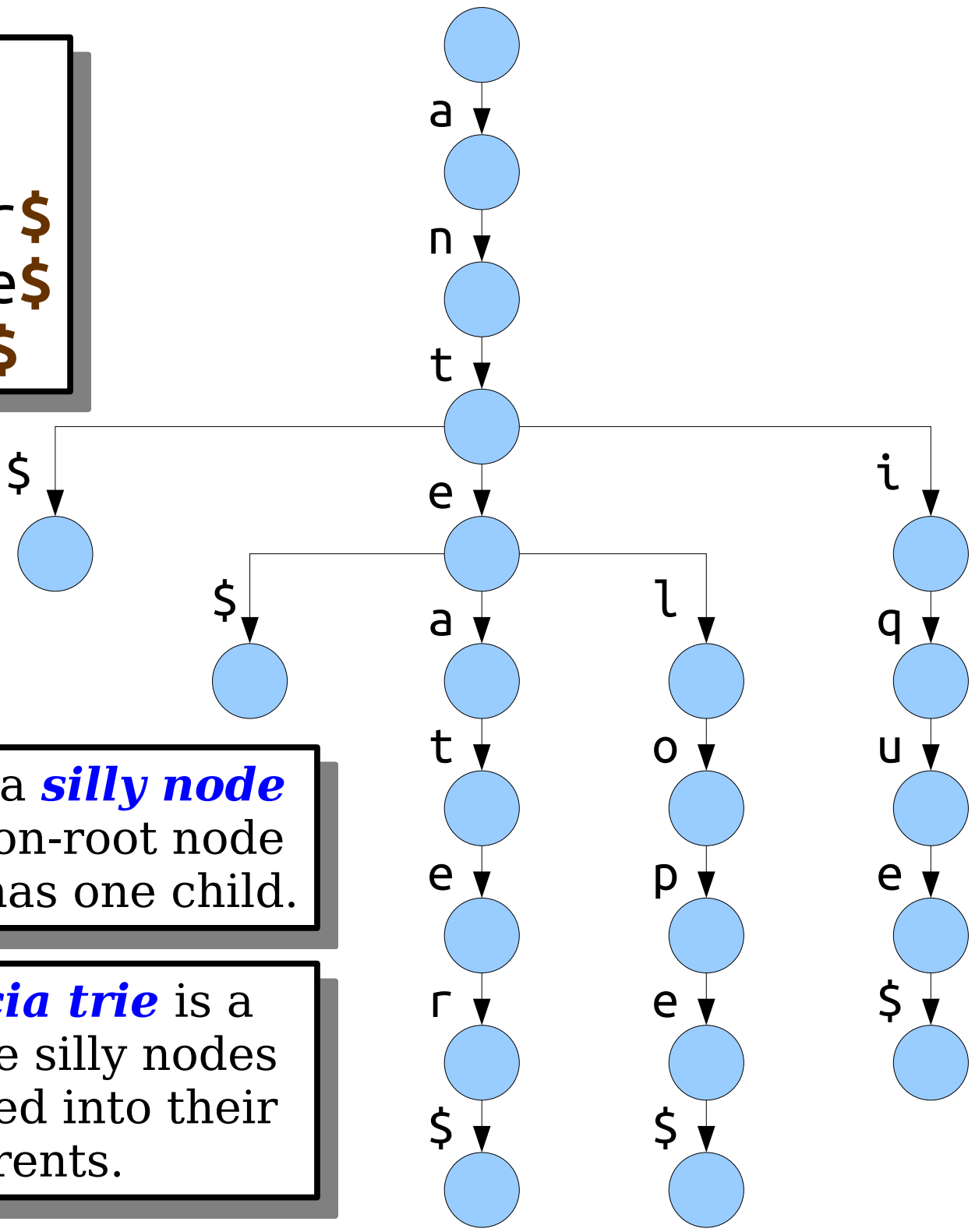

A node is a ***silly node*** if it is a non-root node that only has one child.

A ***Patricia trie*** is a trie where silly nodes are merged into their parents.

ant\$
ante\$
anteater\$
antelope\$
antique\$

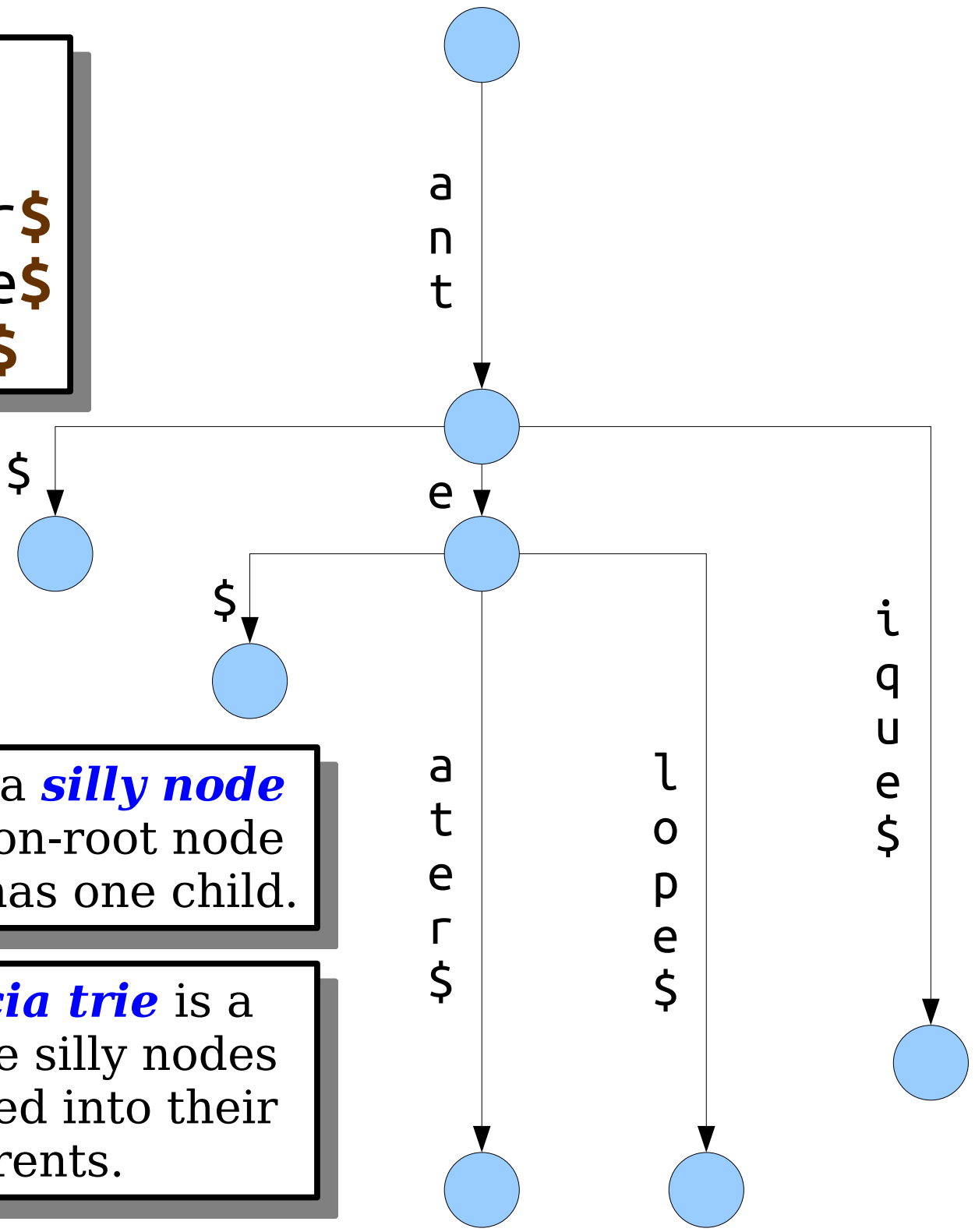

A node is a ***silly node*** if it is a non-root node that only has one child.

A ***Patricia trie*** is a trie where silly nodes are merged into their parents.

ant\$
 ante\$
 anteatere\$
 antelope\$
 antique\$

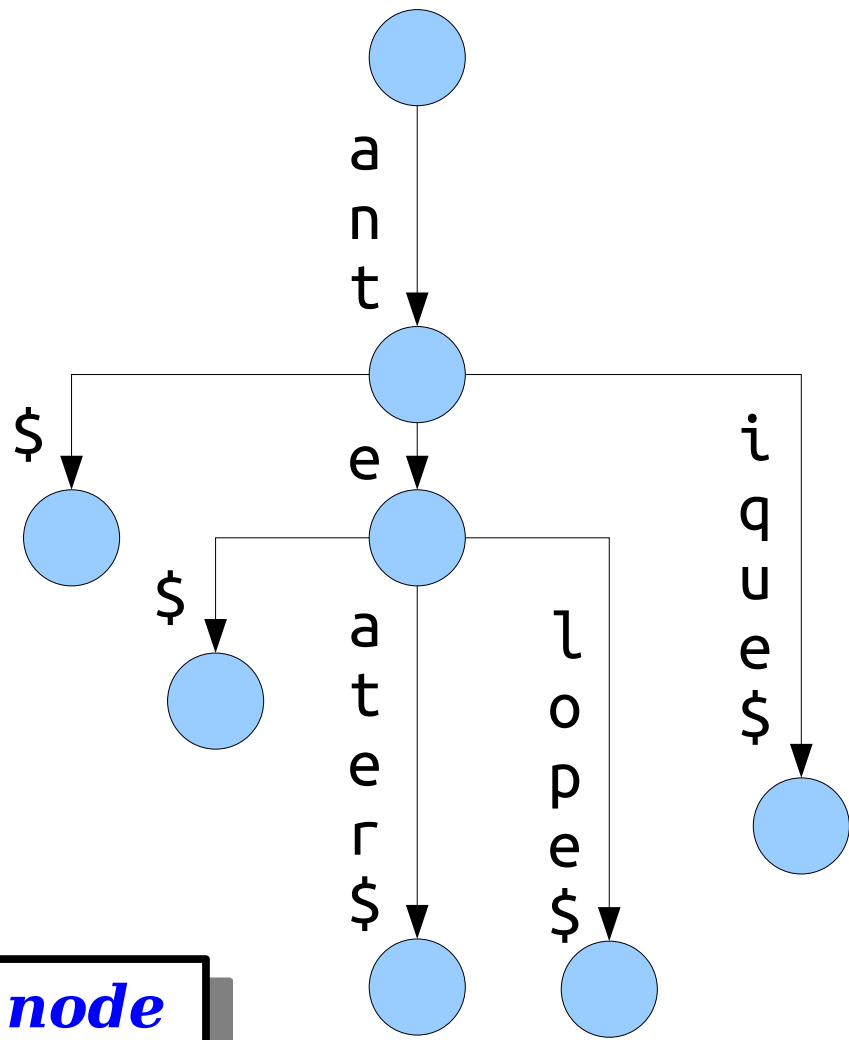

A node is a ***silly node*** if it is a non-root node that only has one child.

A ***Patricia trie*** is a trie where silly nodes are merged into their parents.

ant\$
 ante\$
 anteater\$
 antelope\$
 antique\$

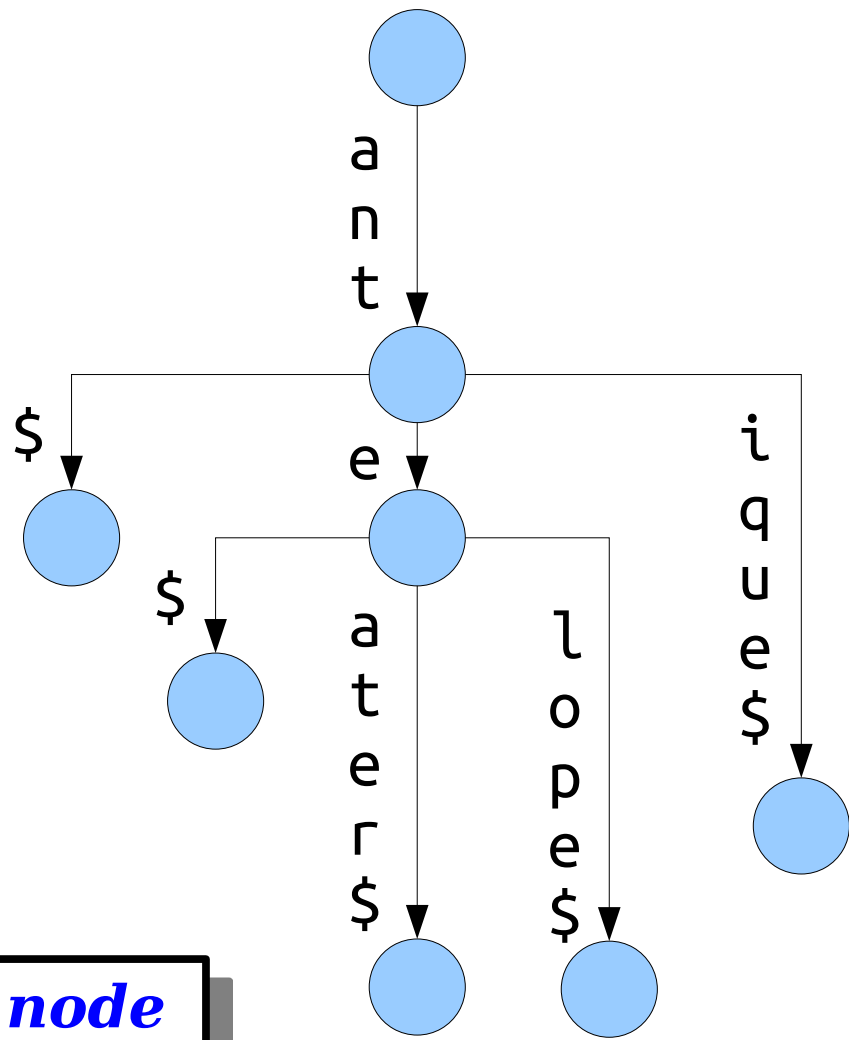

A node is a ***silly node*** if it is a non-root node that only has one child.

A ***Patricia trie*** is a trie where silly nodes are merged into their parents.

Observation 1: Every internal node in a Patricia trie (except possibly the root) has two or more children.

ant\$
 ante\$
 anteater\$
 antelope\$
 antique\$

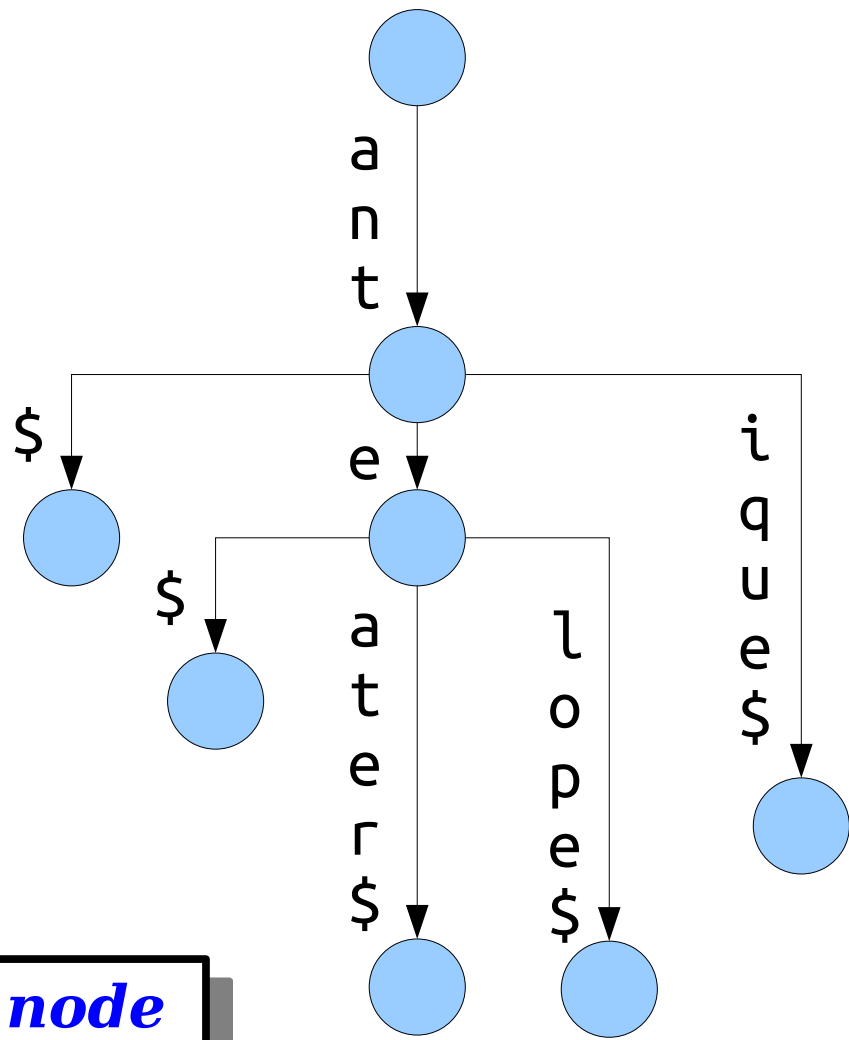

A node is a ***silly node*** if it is a non-root node that only has one child.

A ***Patricia trie*** is a trie where silly nodes are merged into their parents.

Observation 2:
 Leaves correspond to words; internal nodes are there for routing purposes.

Patricia Tries

- **Theorem:** The number of nodes in a Patricia trie with k words is always $O(k)$, regardless of what those words are.

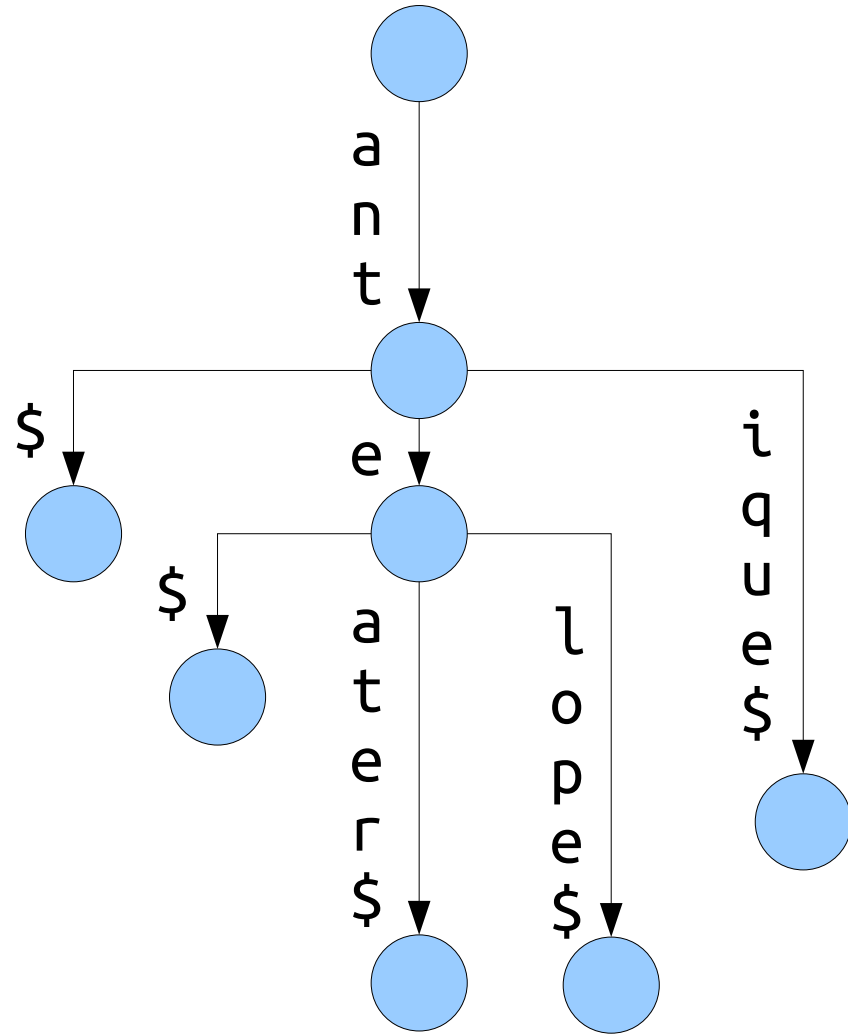

Patricia Tries

- **Theorem:** The number of nodes in a Patricia trie with k words is always $O(k)$, regardless of what those words are.

Why?

Answer at

<https://pollev.com/cs166spr23>

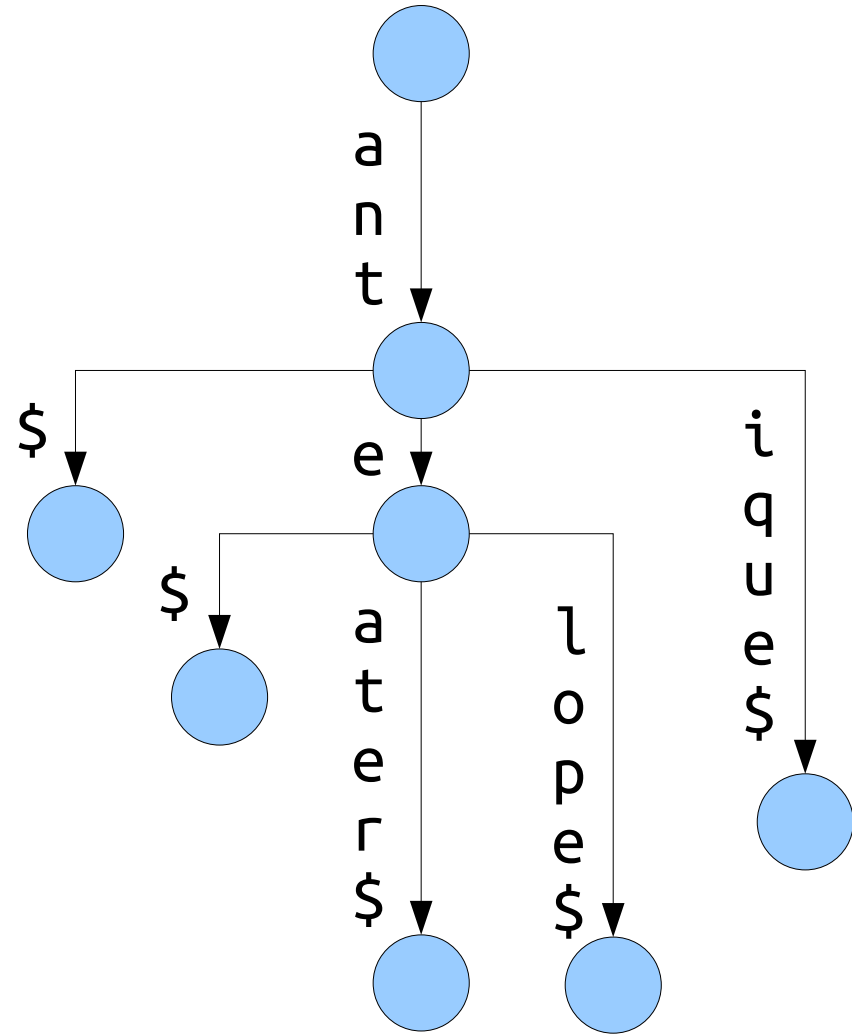

Patricia Tries

- **Theorem:** The number of nodes in a Patricia trie with k words is always $O(k)$, regardless of what those words are.

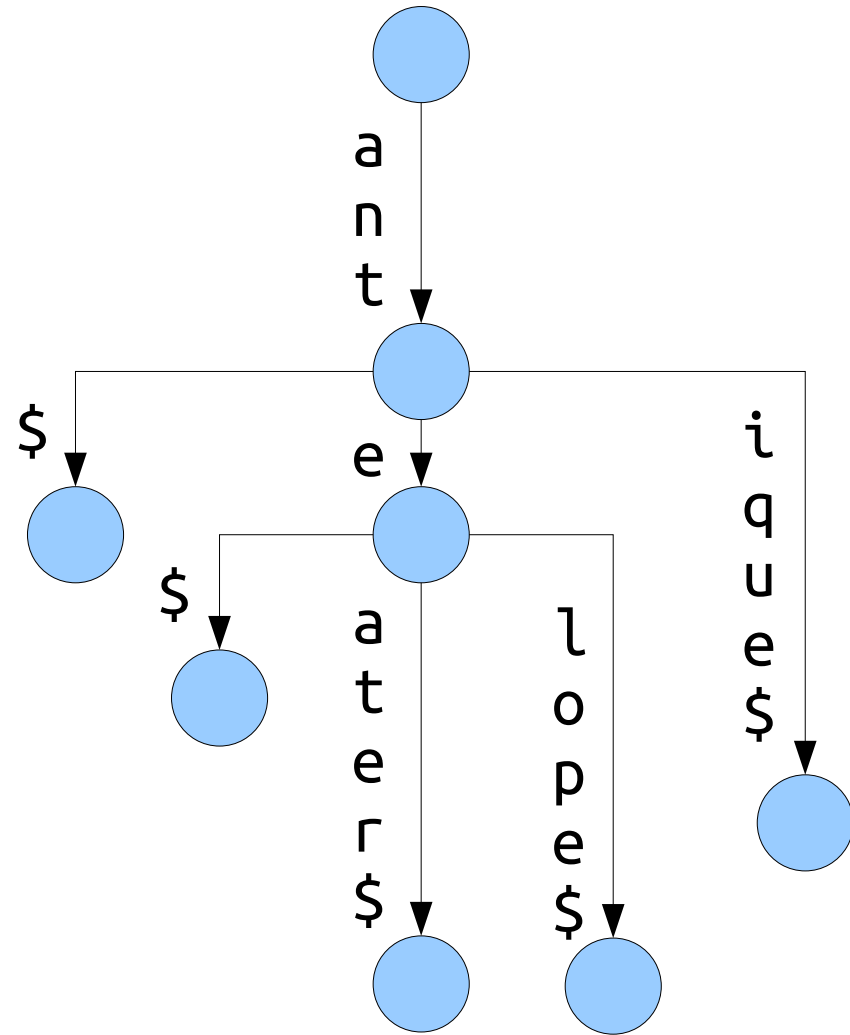

Patricia Tries

- **Theorem:** The number of nodes in a Patricia trie with k words is always $O(k)$, regardless of what those words are.

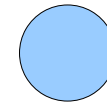
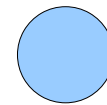

There are k leaves, one per word in the trie.

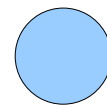
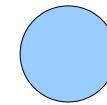
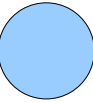

Patricia Tries

- **Theorem:** The number of nodes in a Patricia trie with k words is always $O(k)$, regardless of what those words are.

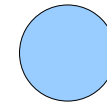
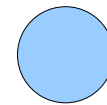

Think of this as a forest of k different trees.

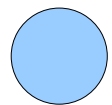
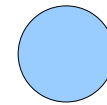

Patricia Tries

- **Theorem:** The number of nodes in a Patricia trie with k words is always $O(k)$, regardless of what those words are.

Adding an internal node merges two or more trees together, decreasing the number of trees by at least one.

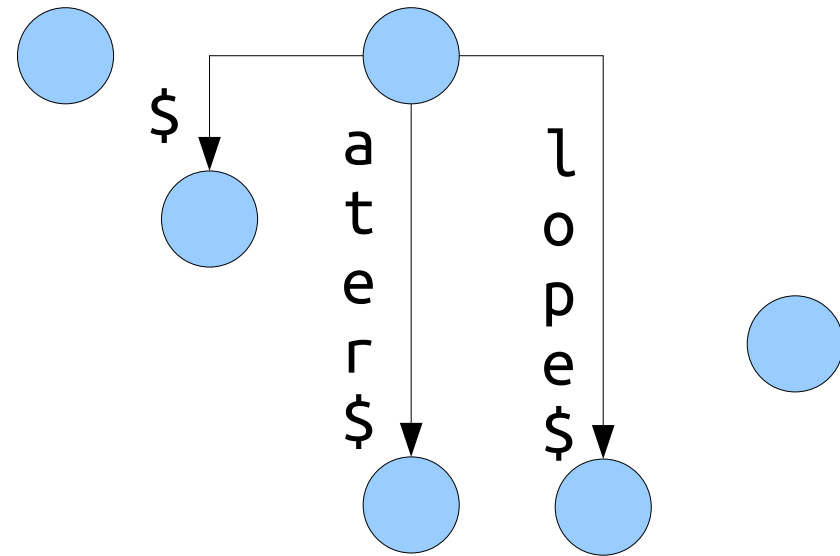

Patricia Tries

- **Theorem:** The number of nodes in a Patricia trie with k words is always $O(k)$, regardless of what those words are.

Adding the root might not decrease the number of trees, but there's only one root.

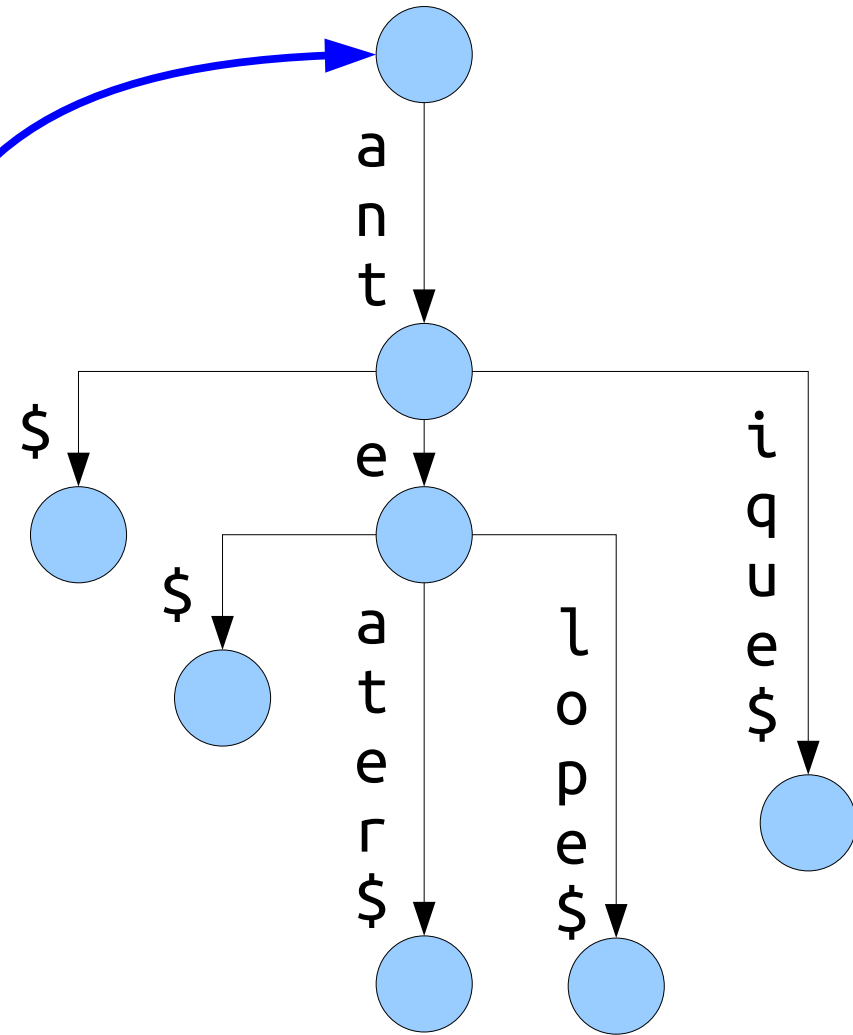

Patricia Tries

- **Theorem:** The number of nodes in a Patricia trie with k words is always $O(k)$, regardless of what those words are.
- **Proof Sketch:** There are k leaves, one per word. Remove all internal nodes, leaving a forest of k trees.

Add the internal nodes back one at a time. Each addition (except possibly root) decreases the number of trees in the forest by at least one, since each (non-root) internal node has at least two children. This means there are at most k internal nodes, for a total of $O(k)$ nodes. ■

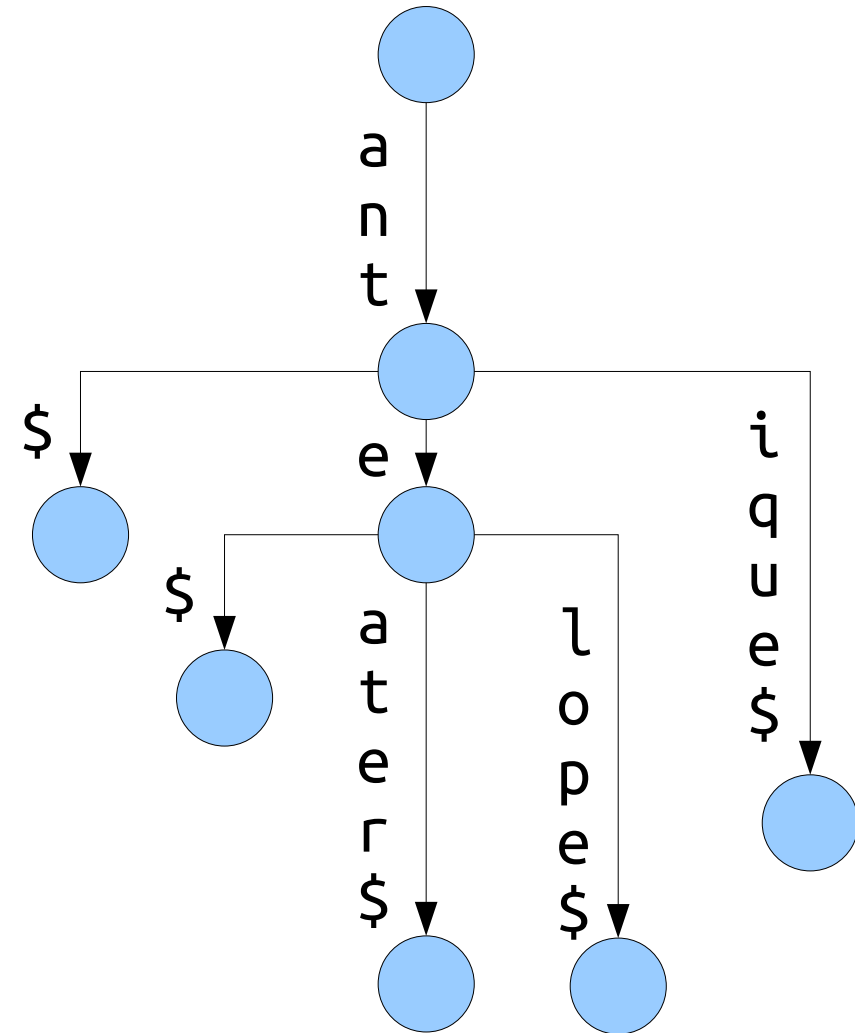

Patricia Tries

- **Claim:** If each leaf in a Patricia trie is annotated with the index of the word it comes from, the indices of strings starting with a given prefix can be found in time $O(n + z)$, where n is the length of that prefix and z is the number of matches.
- **Question:** How is this possible?

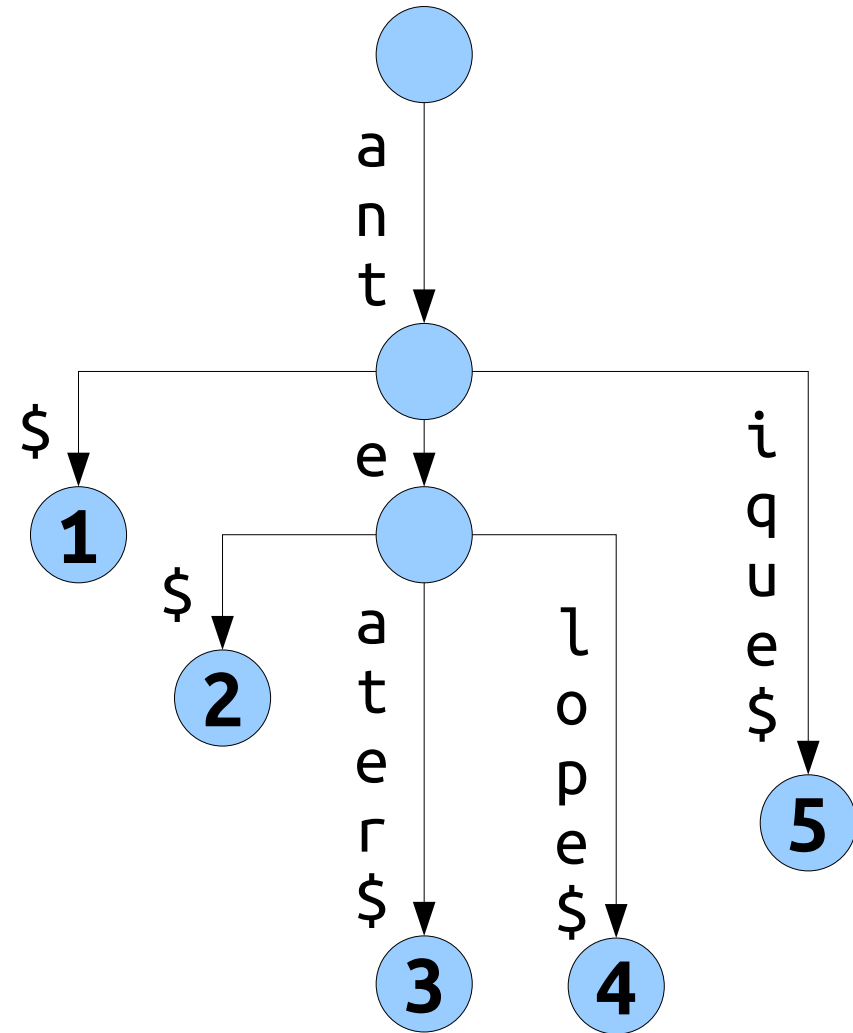

Answer at

<https://pollev.com/cs166spr23>

Patricia Tries

- Use a two-phase search algorithm!
- **(Character-aware)** Read the prefix to search for, matching characters as you walk down the Patricia trie.
 - Time required: $O(n)$, since we have to read all the characters of the prefix.
- **(Character-blind)** If you didn't walk off the trie, do a DFS below your current point to find all leaves, ignoring the strings on the edges.
 - Time required: $O(z)$. If there are z matches, there are z leaves to explore. As we saw earlier, in a Patricia trie, a subtree with z leaves has $O(z)$ total nodes.

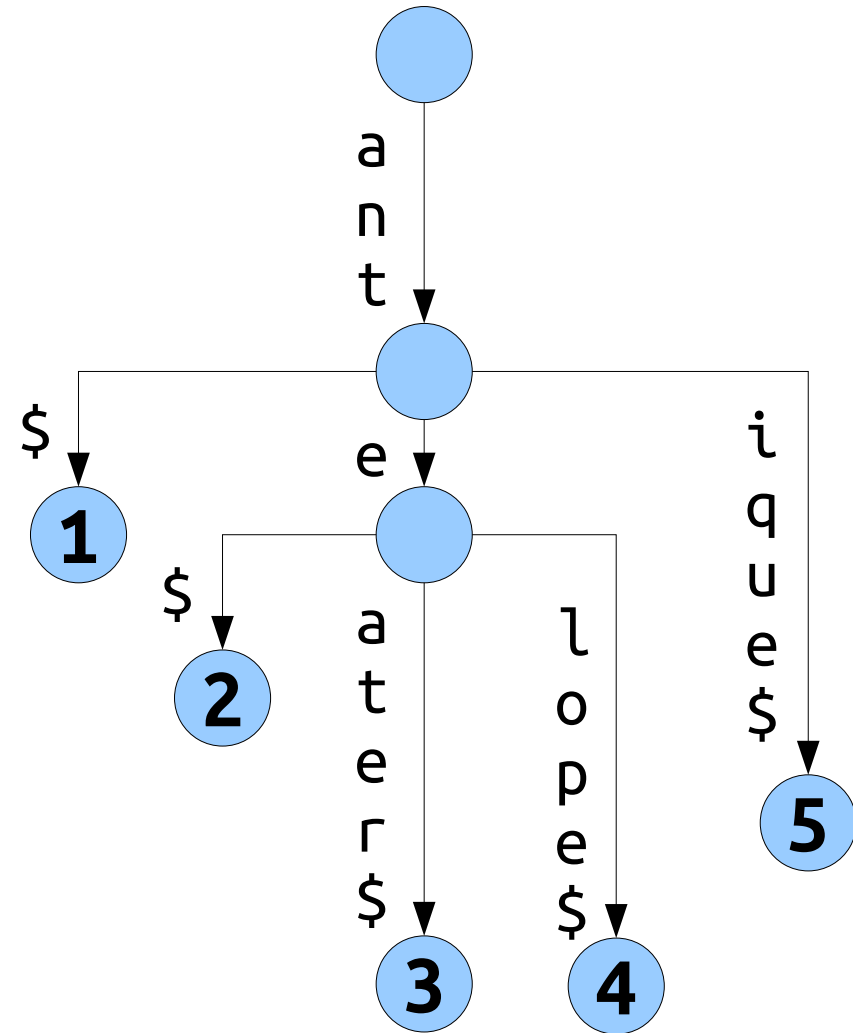

The Story So Far

- Adopting our notation from RMQ, a Patricia trie gives an $\langle O(m), O(n + z) \rangle$ solution to prefix matching.
- Those runtimes hide the effect of the alphabet size; take some time to evaluate those tradeoffs!

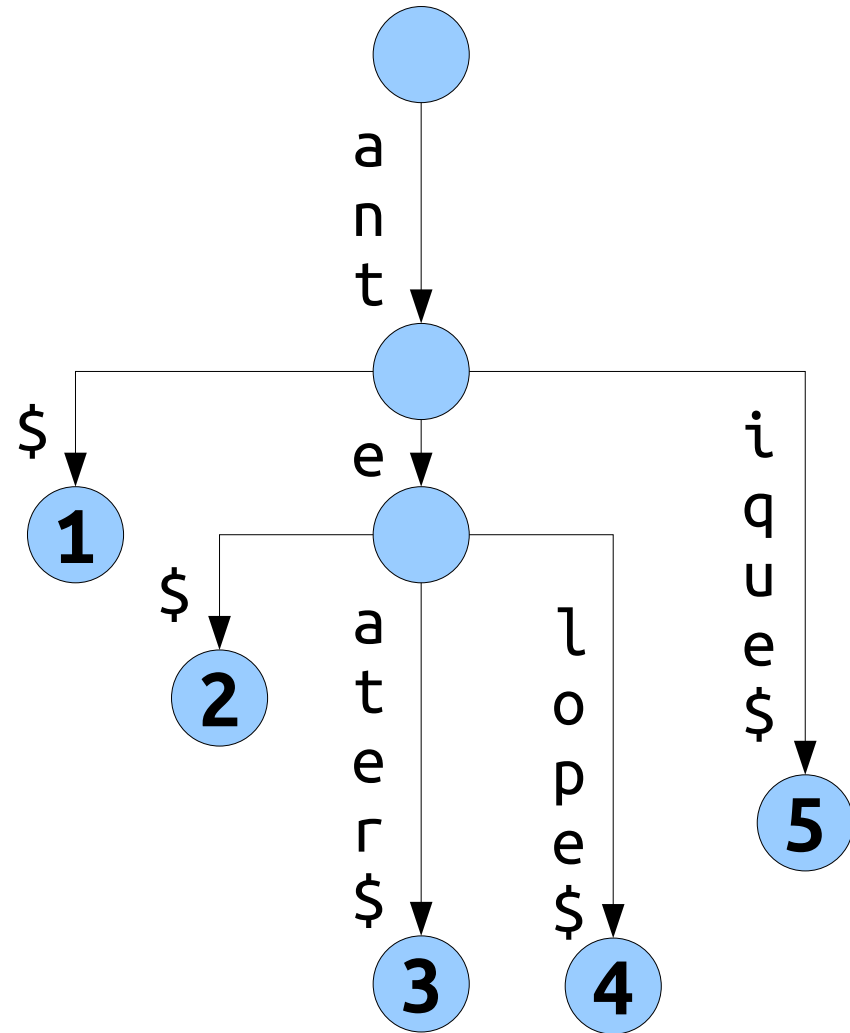

Part II: *Suffix Trees*

Two Motivating Problems



The *United States Statutes at Large* contains all legislation ever passed in the United States.

Make it searchable.



Cancers often have repeated copies the same gene.

Given a cancer genome (length $\sim 3,000,000,000$),
find the longest repeated DNA sequence.

Patricia tries are great tools for finding *prefixes*.

These problems involve looking for *substrings*.

Can we use what we've developed so far?

A Fundamental Theorem

- The ***fundamental theorem of stringology*** says that, given two strings w and x , that

w is a substring of x
if and only if
 w is a prefix of a suffix of x

b	e
---	---

f	l	i	b	b	e	r	t	i	g	i	b	b	e	t
---	---	---	---	---	---	---	---	---	---	---	---	---	---	---

A Fundamental Theorem

- The ***fundamental theorem of stringology*** says that, given two strings w and x , that

w is a substring of x
if and only if
 w is a prefix of a suffix of x

b	e
---	---

f	l	i	b	b	e	r	t	i	g	i	b	b	e	t
---	---	---	---	---	---	---	---	---	---	---	---	---	---	---

A Fundamental Theorem

- The ***fundamental theorem of stringology*** says that, given two strings w and x , that

w is a substring of x
if and only if
 w is a prefix of a suffix of x

b	e
---	---

f	l	i	b	b	e	r	t	i	g	i	b	b	e	t
---	---	---	---	---	---	---	---	---	---	---	---	---	---	---

A Fundamental Theorem

- The ***fundamental theorem of stringology*** says that, given two strings w and x , that

w is a substring of x
if and only if
 w is a prefix of a suffix of x

b	e
---	---

f	l	i	b	b	e	r	t	i	g	i	b	b	e	t
---	---	---	---	---	---	---	---	---	---	---	---	---	---	---

A Fundamental Theorem

- The ***fundamental theorem of stringology*** says that, given two strings w and x , that

w is a substring of x
if and only if
 w is a prefix of a suffix of x

b	e
---	---

f	l	i	b	b	e	r	t	i	g	i	b	b	e	t
---	---	---	---	---	---	---	---	---	---	---	---	---	---	---

A Fundamental Theorem

- The ***fundamental theorem of stringology*** says that, given two strings w and x , that

w is a substring of x
if and only if
 w is a prefix of a suffix of x

b	e
---	---

f	l	i	b	b	e	r	t	i	g	i	b	b	e	t
---	---	---	---	---	---	---	---	---	---	---	---	---	---	---

A Fundamental Theorem

- The ***fundamental theorem of stringology*** says that, given two strings w and x , that

w is a substring of x
if and only if

w is a prefix of a suffix of x

- To find all matches of w in x , we just need to find all suffixes of x that start with w .

nonsense\$
 onsense\$
 nsense\$
 sense\$
 ense\$
 nse\$
 se\$
 e\$
 \$

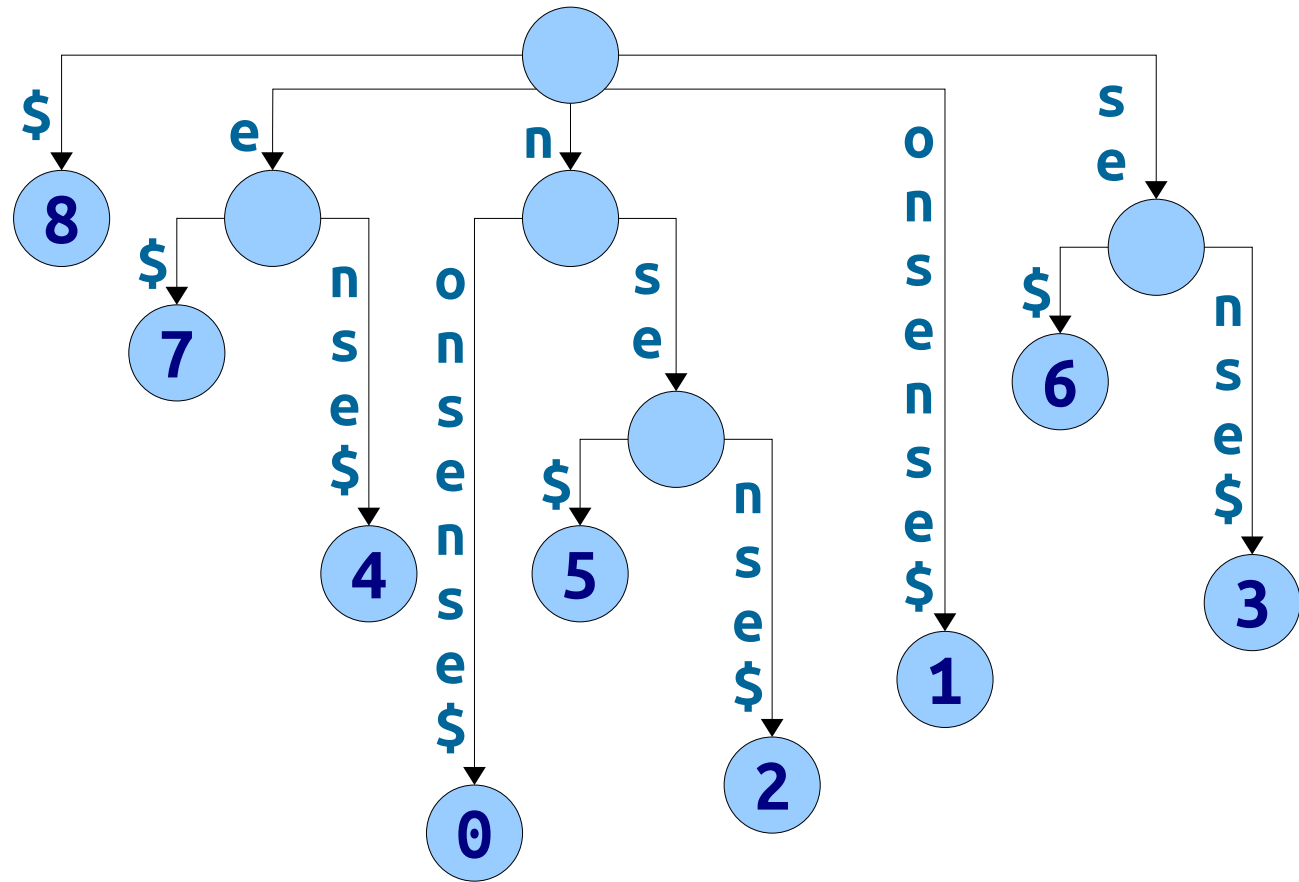

nonsense\$
 012345678

Suffix Trees

- A **suffix tree** for a string T is a Patricia trie of all suffixes of T .
- Each leaf is labeled with the starting index of that suffix.
- Two facts:
 - It's possible to build a suffix tree from a string of length m in time $O(m)$. (Yes, really!)
 - It's possible to store a suffix tree for a string of length m using $O(m)$ words of memory. (Yes, really!)

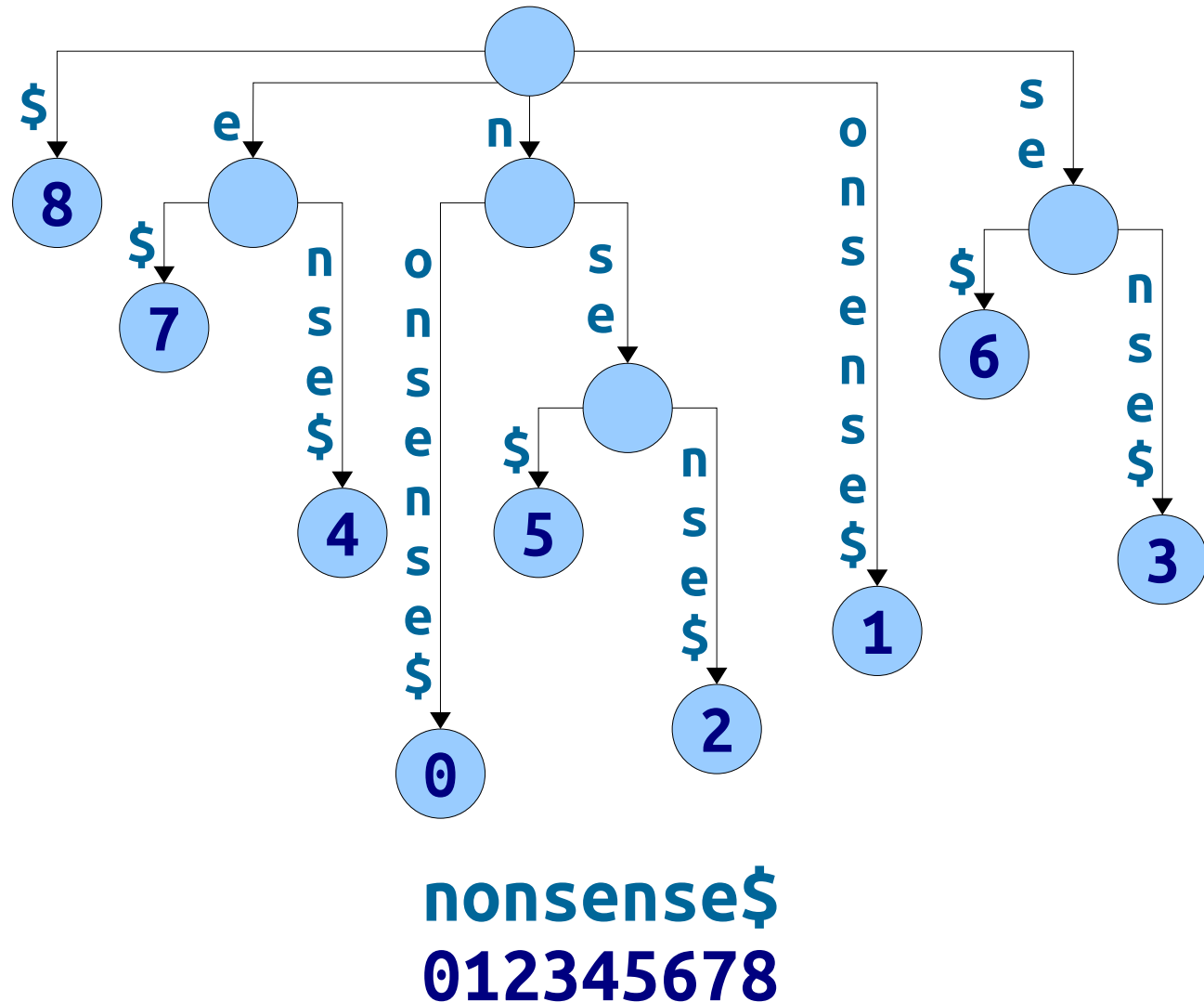

Substring Search

- **Claim:** Once we have a suffix tree for a string T , we can find all matches of a pattern P of length n in time $O(n + z)$, where z is the number of matches.
- **Idea:** Use the standard Patricia trie search from before!

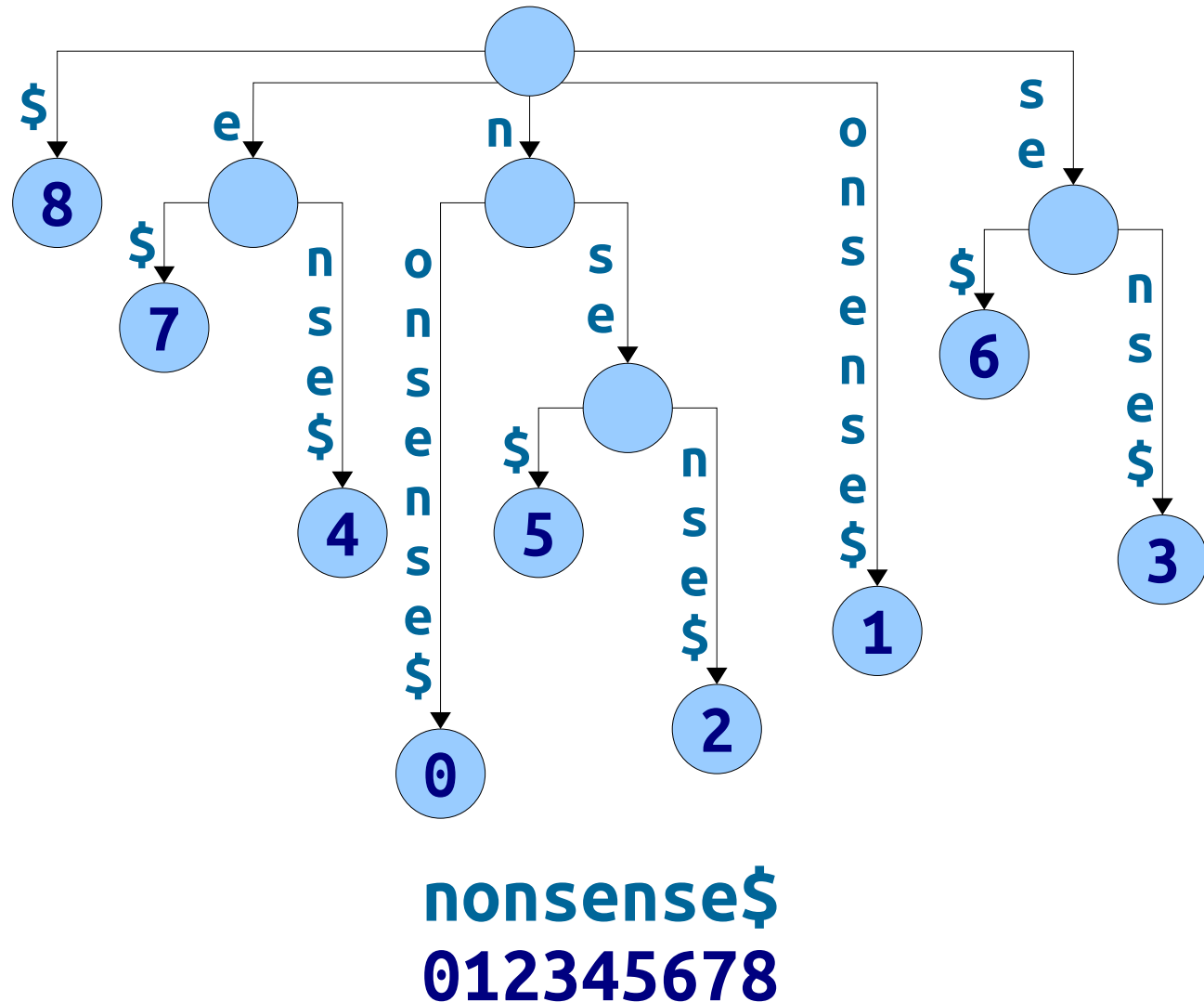

Substring Search

- **Algorithm:** Use the standard Patricia trie search!
- Look up the pattern in the suffix tree, then use a DFS to find all matches.
- Looking up the pattern takes time $O(n)$.
- Finding all matches takes time $O(z)$.

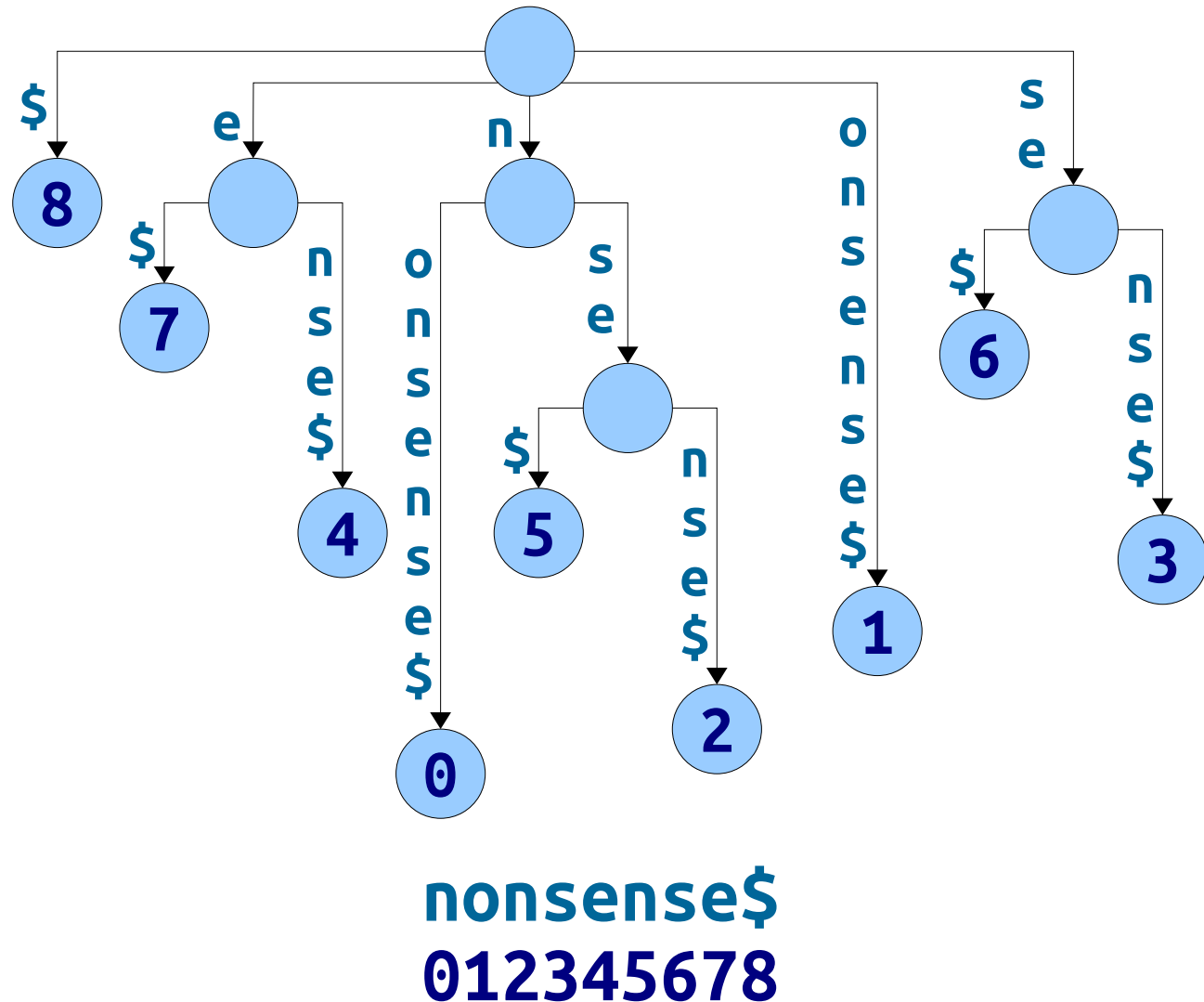



Cancers often have repeated copies the same gene.

Given a cancer genome (length $\sim 3,000,000,000$),
find the longest repeated DNA sequence.

The Anatomy of a Suffix Tree

- Think back to Cartesian trees. We can describe them in two ways.
 - **Mechanically:** Hoist the minimum element up to the root, then recursively process the two subarrays.
 - **Operationally:** It's a min-heap whose inorder traversal gives the original array.
- We now have a **mechanical** definition of a suffix tree. Can we get an **operational** one?

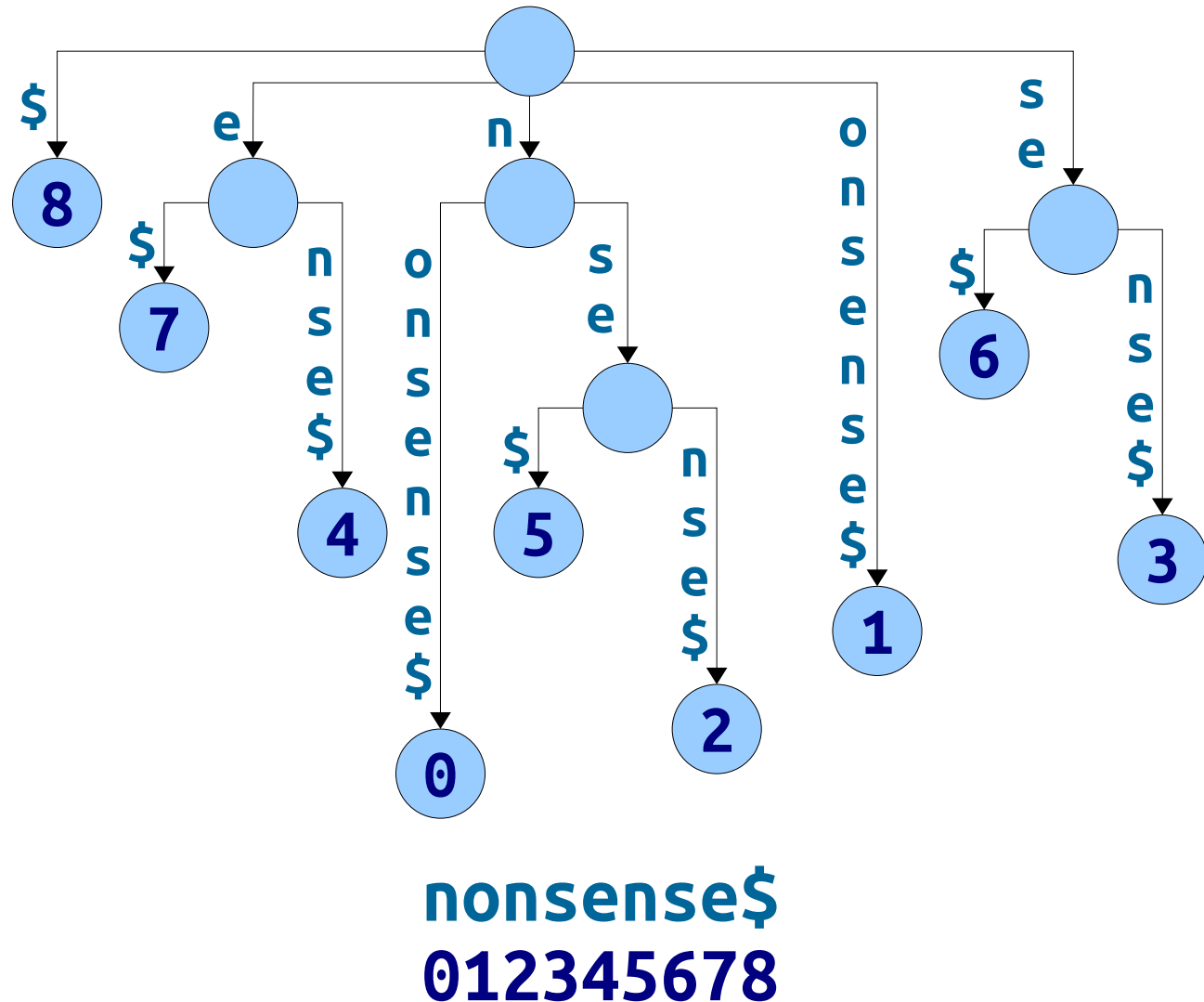

The Anatomy of a Suffix Tree

- The leaves of a suffix tree correspond to the suffixes of the text string T .
- **Question:** What do the *internal* nodes of the suffix tree correspond to?

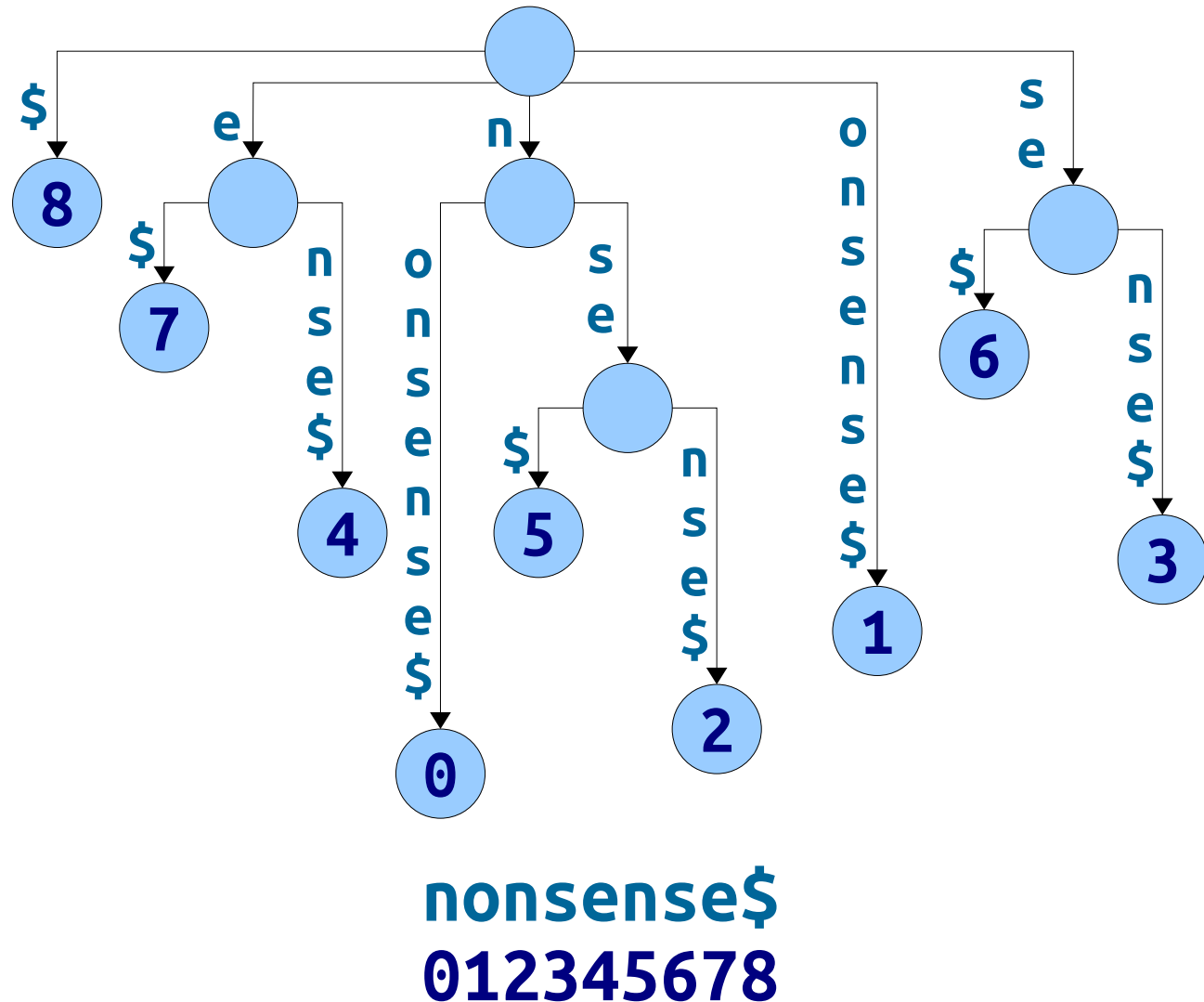

The Anatomy of a Suffix Tree

- In this suffix tree, there are internal nodes for the substrings **e**, **n**, **nse**, and **se**.
- All these substrings appear at least twice in the original string!
- More generally: if there is an internal node for a substring α , then α appears at least twice in the original text.

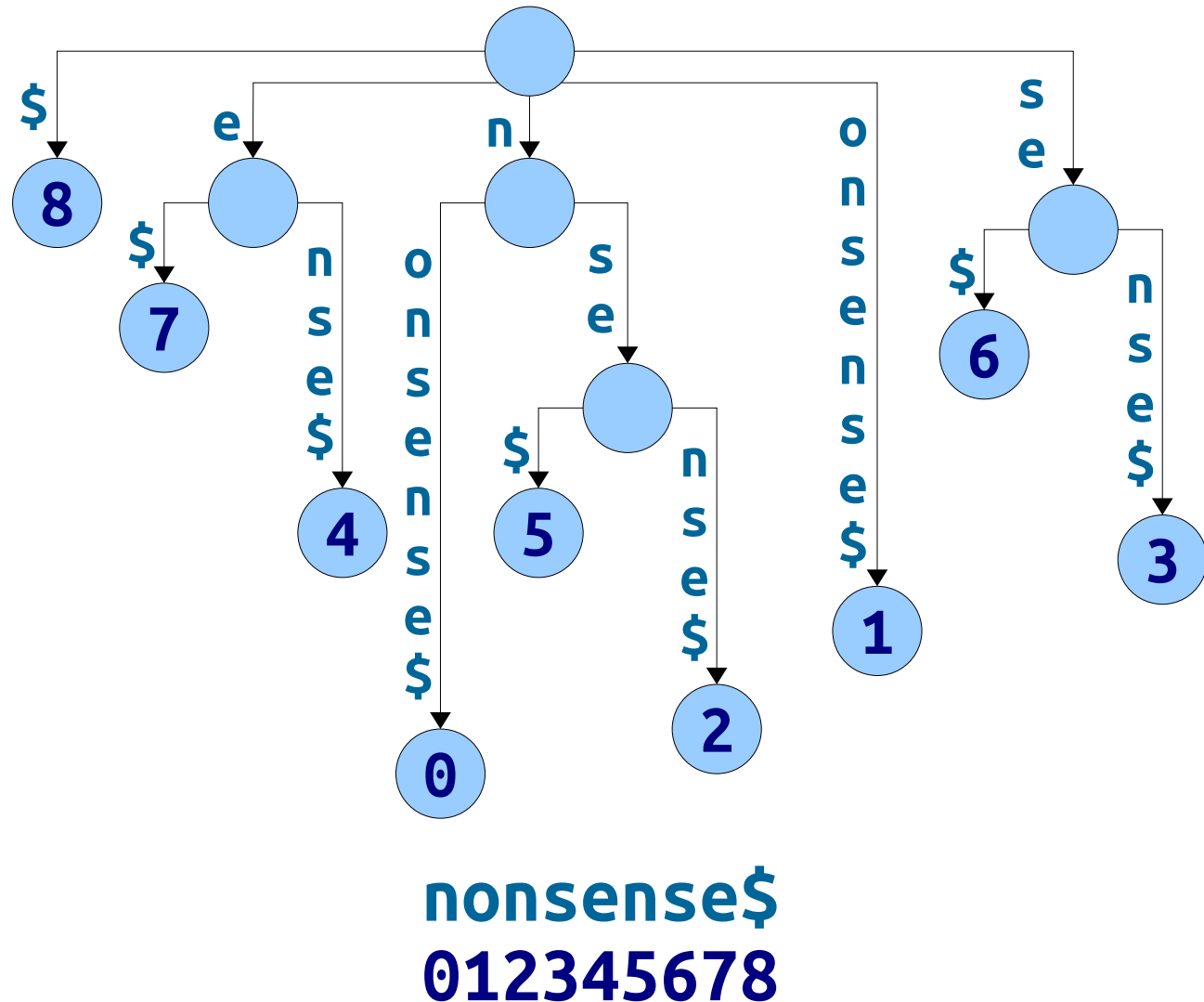

The Anatomy of a Suffix Tree

- Question:** why is there an internal node for the substring **n**, but *isn't* there an internal node for the substring **ns**?

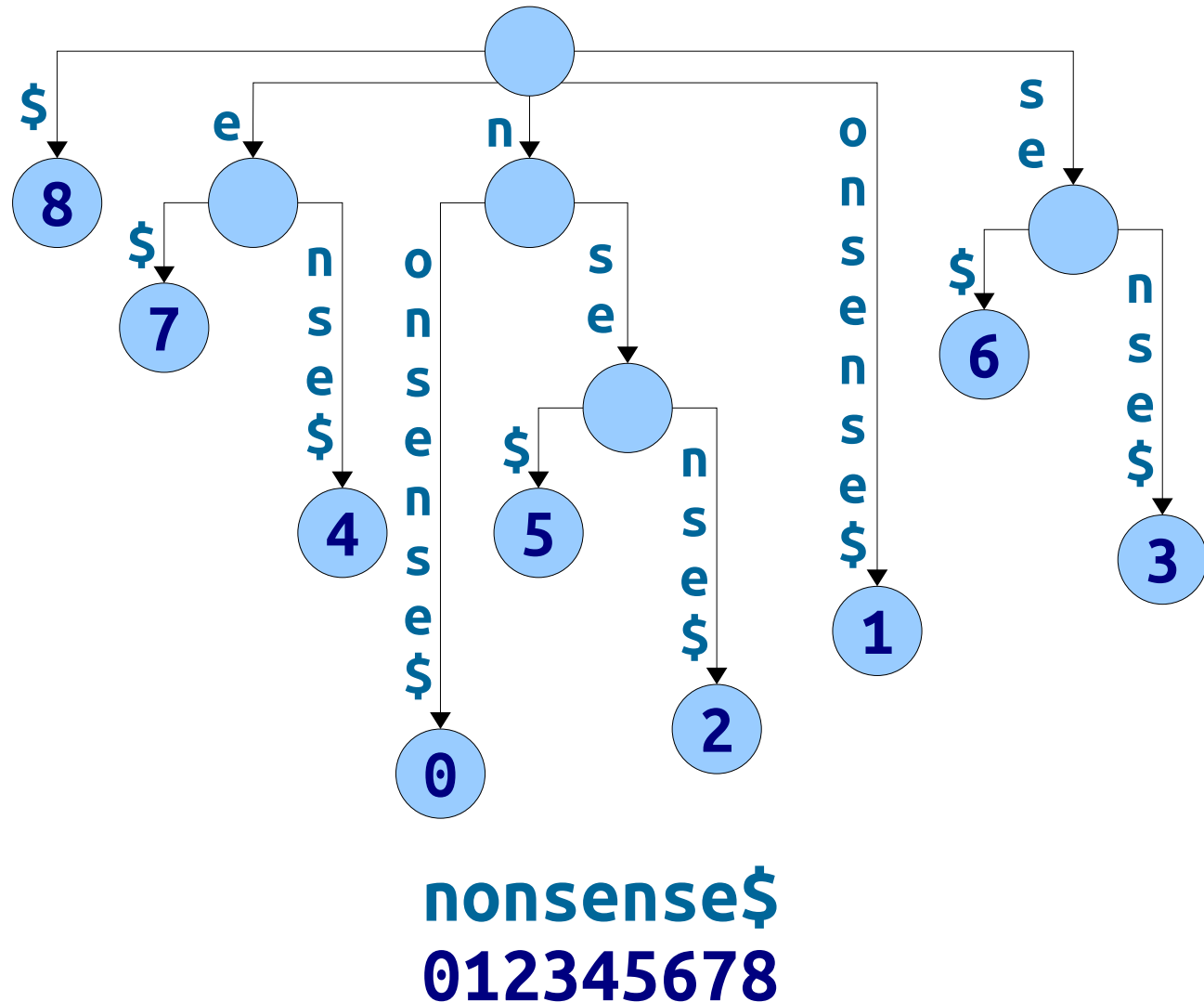

The Anatomy of a Suffix Tree

- Question:** why is there an internal node for the substring **n**, but *isn't* there an internal node for the substring **ns**?

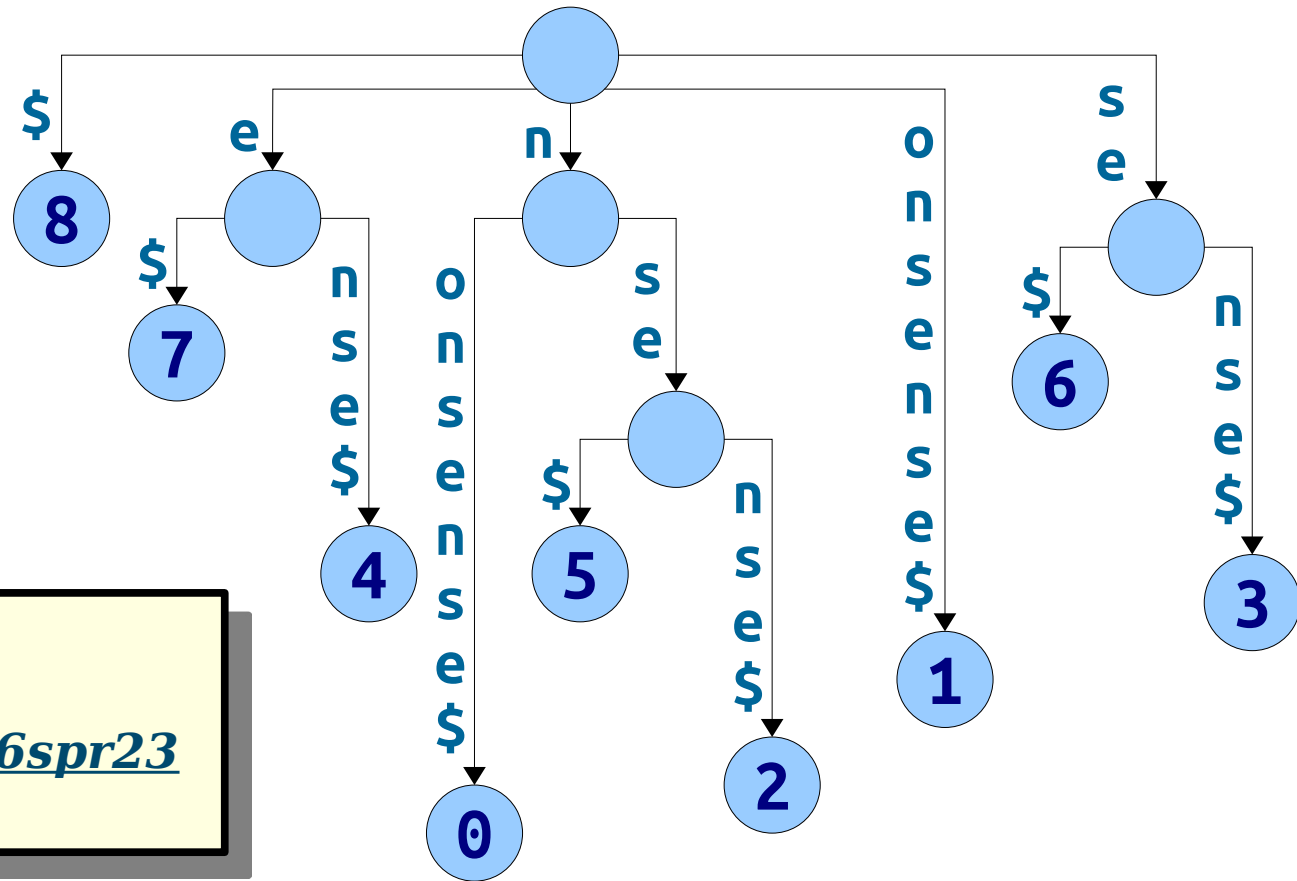

nonsense\$
012345678

Answer at
<https://pollev.com/cs166spr23>

The Anatomy of a Suffix Tree

- **Question:** why is there an internal node for the substring **n**, but *isn't* there an internal node for the substring **ns**?
- Every occurrence of **ns** can be extended by appending the same character (**e**).
- *Not all* occurrences of **n** can be extended by appending the same character.

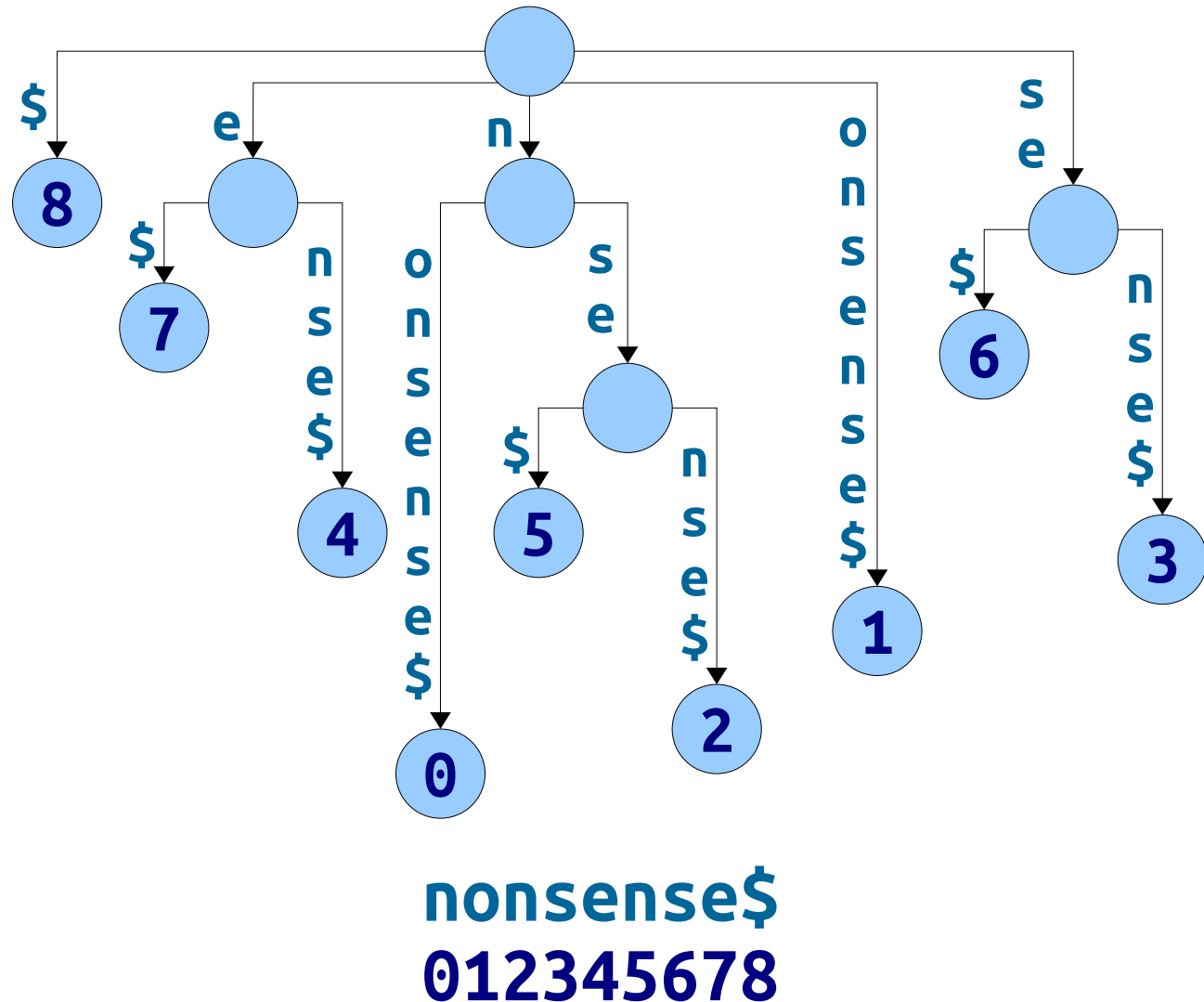

The Anatomy of a Suffix Tree

- A **branching word** in $T\$$ is a string ω such that there are characters $a \neq b$ where ωa and ωb are substrings of $T\$$.
 - Edge case: the empty string is always considered branching.
- **Theorem:** The suffix tree for a string T has an internal node for a string ω if and only if ω is a branching word in $T\$$.

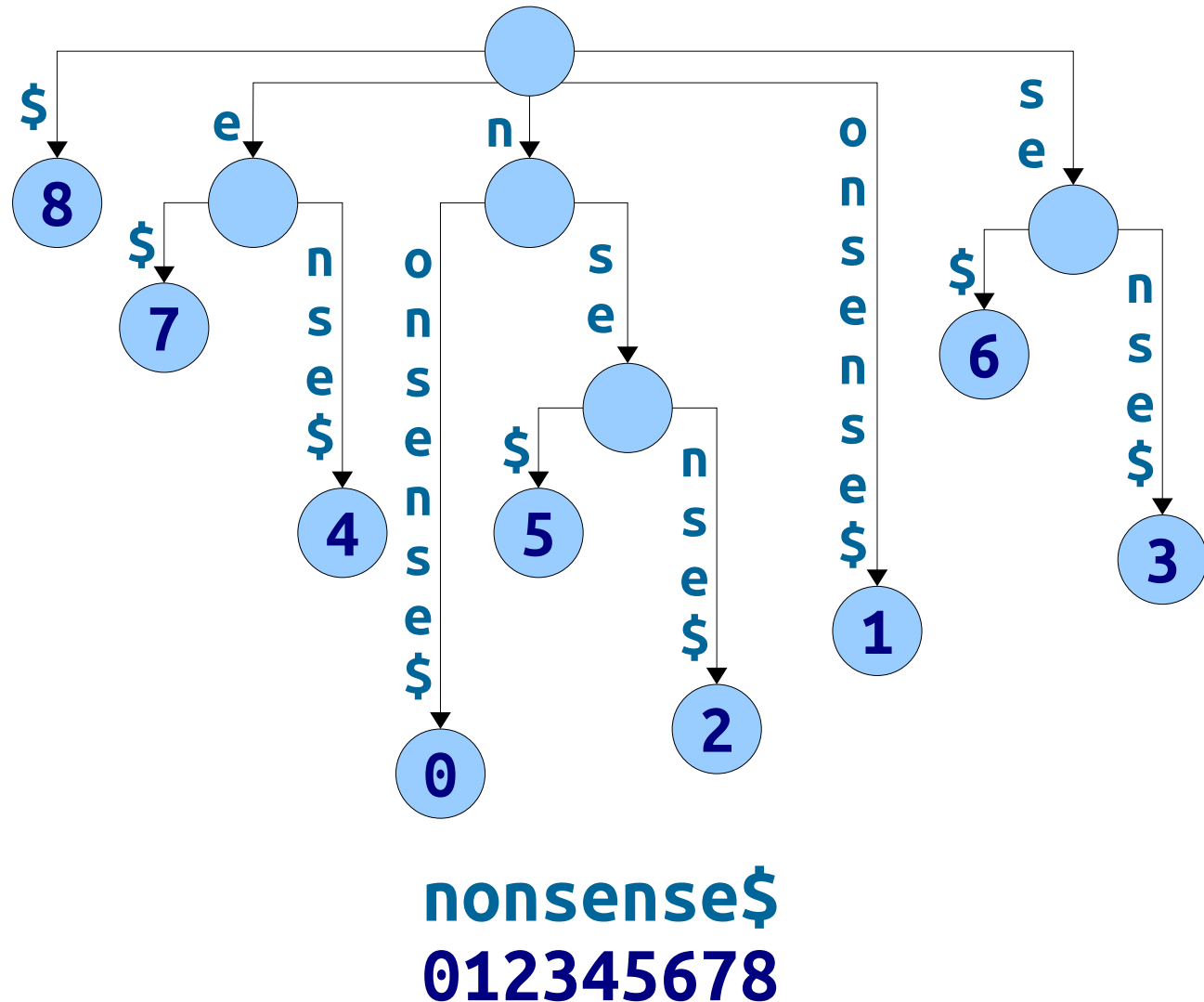

The Anatomy of a Suffix Tree

- Combining our previous points together, we can give a (partial) operational definition of a suffix tree:

The leaves of a suffix tree for T correspond to suffixes of $T\$$, and the internal nodes of a suffix tree for T correspond to branching words of $T\$$.

- We'll make extensive use of this fact going forward.

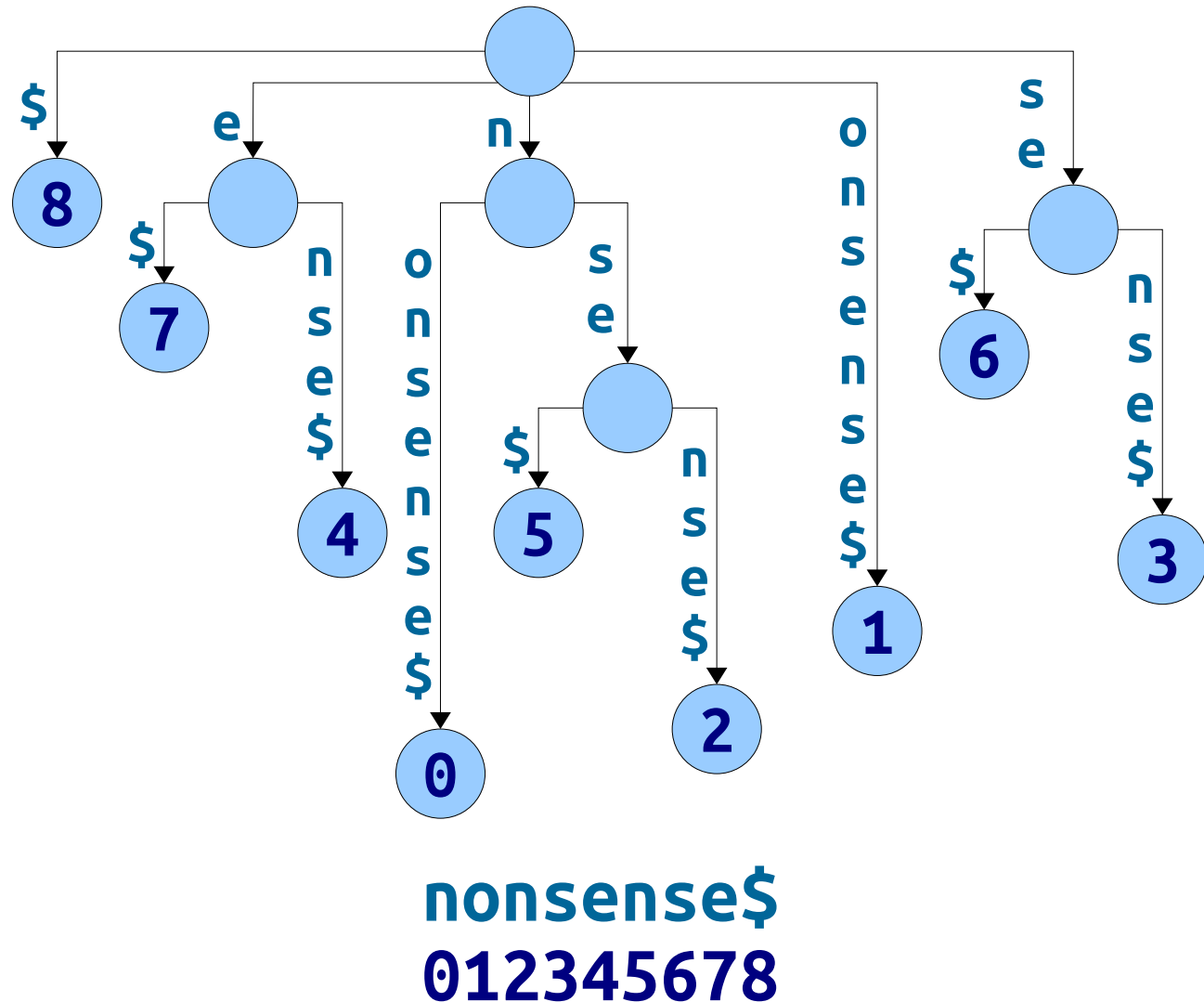

Longest Repeated Substrings

- **Theorem:** The longest repeated substring of a string T must be a branching word in $T\$$.
- **Proof idea:** If ω isn't branching, it can't be the longest repeated substring.

f	l	i	b	b	e	r	t	i	g	i	b	b	e	t
---	---	---	---	---	---	---	---	---	---	---	---	---	---	---

Longest Repeated Substrings

- **Theorem:** The longest repeated substring of a string T must be a branching word in $T\$$.
- **Proof idea:** If ω isn't branching, it can't be the longest repeated substring.

The substring `berti` isn't repeated.

It therefore can't be the longest repeated substring.

f	l	i	b	b	e	r	t	i	g	i	b	b	e	t
---	---	---	---	---	---	---	---	---	---	---	---	---	---	---

Longest Repeated Substrings

- **Theorem:** The longest repeated substring of a string T must be a branching word in $T\$$.
- **Proof idea:** If ω isn't branching, it can't be the longest repeated substring.

f	l	i	b	b	e	r	t	i	g	i	b	b	e	t
---	---	---	---	---	---	---	---	---	---	---	---	---	---	---

Longest Repeated Substrings

- **Theorem:** The longest repeated substring of a string T must be a branching word in $T\$$.
- **Proof idea:** If ω isn't branching, it can't be the longest repeated substring.

Every instance of bb
can be extended to bbe.
It therefore can't be the
longest repeated
substring.

f	l	i	b	b	e	r	t	i	g	i	b	b	e	t
---	---	---	---	---	---	---	---	---	---	---	---	---	---	---

Longest Repeated Substrings

- Given a suffix tree for a string T of length m , there is an $O(m)$ -time algorithm for finding the longest repeated substring of T .
- Basic idea:** Run a DFS over the tree and find the internal node with the longest string on its path from the root.
- There are some subtle details required to get this to run in time $O(m)$. Think this over! See what you find.

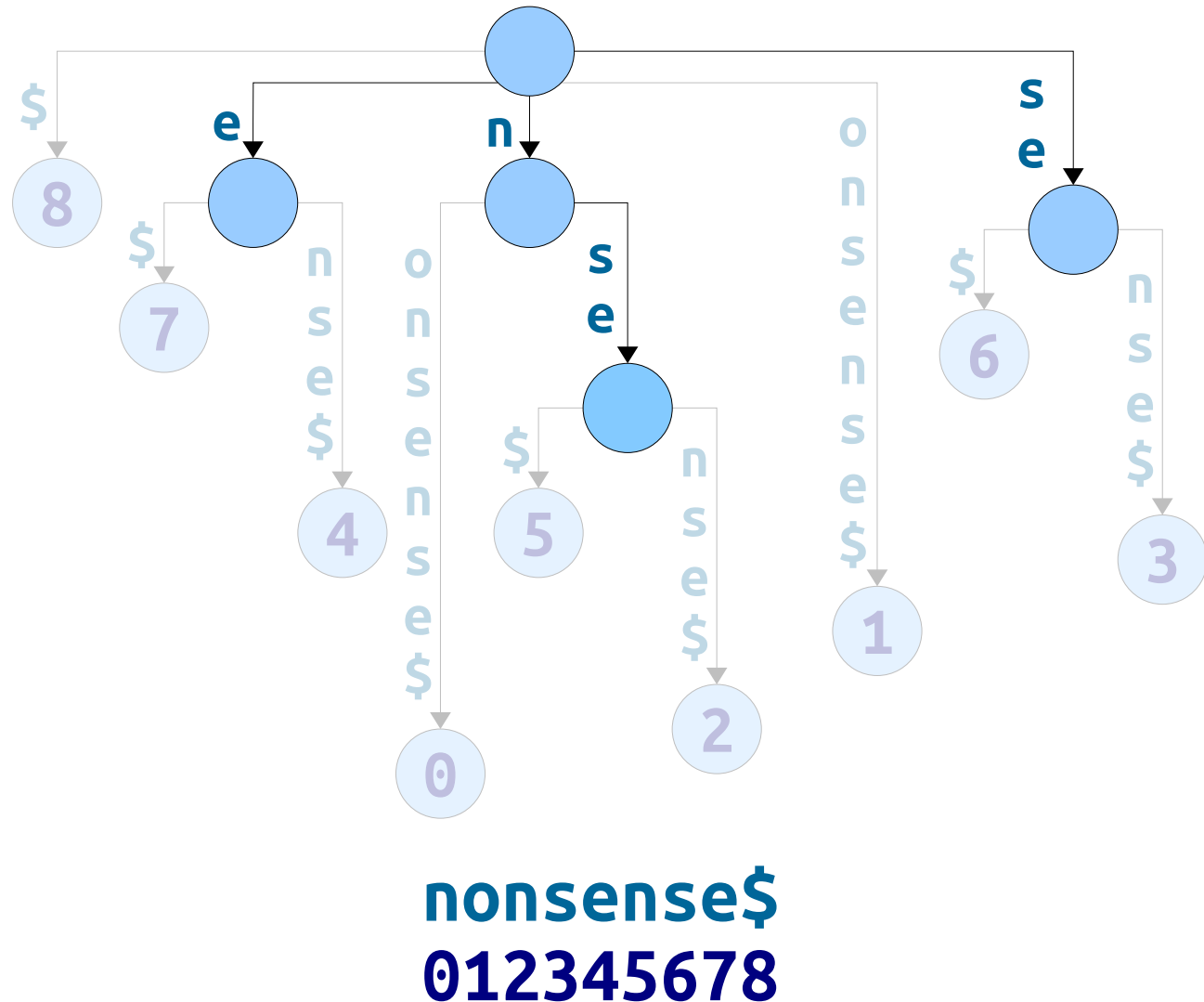

Longest Repeated Substrings

- Given a suffix tree for a string T of length m , there is an $O(m)$ -time algorithm for finding the longest repeated substring of T .
- Basic idea:** Run a DFS over the tree and find the internal node with the longest string on its path from the root.
- There are some subtle details required to get this to run in time $O(m)$. Think this over! See what you find.

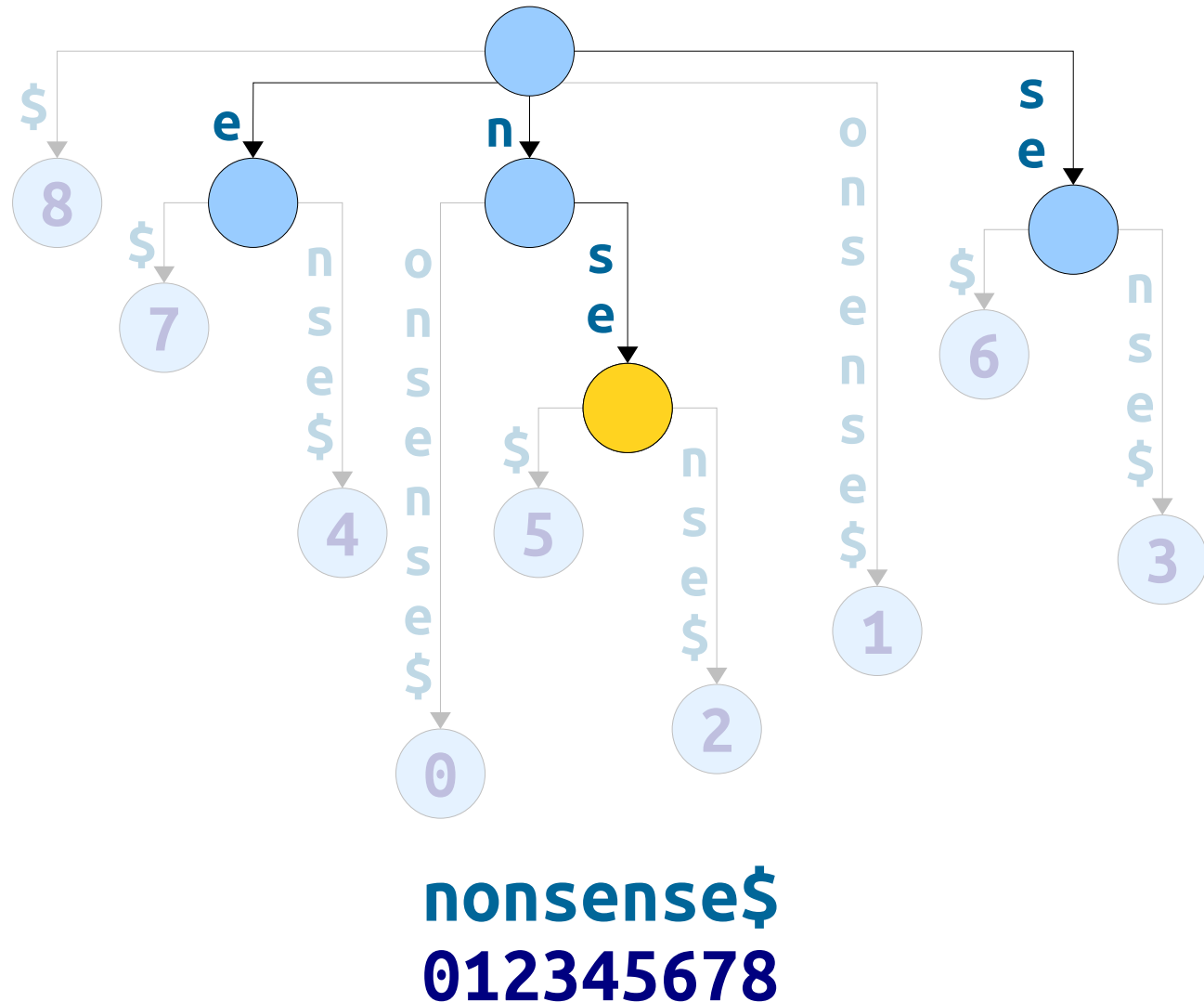

More to Explore

- We've barely scratched the surface of suffix trees. They can be used for tons of other problems.
- A sampling:
 - **Generalized suffix trees**: Solves fast substring searching over multiple text strings, not just a single text string.
 - **Approximate string matching**: Given a text string T and a pattern P , see the closest match to P in T .
 - **Fast matrix multiplication**: The matrix multiplications needed in computing word embeddings can, amazingly, be optimized using suffix trees.
- This is a rich space to explore - and I encourage you to do so!

Next Time

- ***Suffix Arrays***
 - A space-efficient alternative to suffix trees.
- ***LCP Arrays***
 - Implicitly capturing suffix tree structure.